

Shims for thread-turning tool holder

For inserting into thread-turning tool holder no. 17745-17747

ATORN[®]

Application

For inserting into thread-turning tool holder no. 17745-17747. Sets the thread-turning insert at the correct angle.

Version

- Shims for thread-turning tool holder

Advantage

- Precision-ground for a high degree of dimensional accuracy

Delivery

Shim

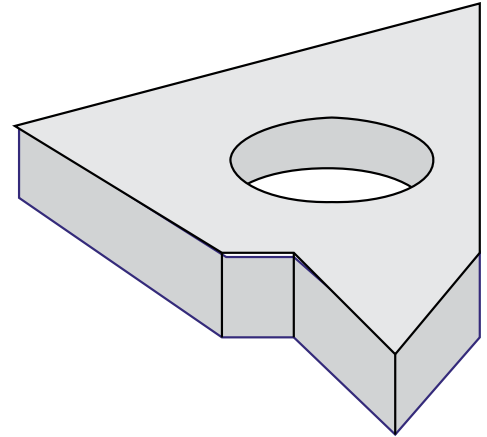

| | |
|---|------------------|
| Art. no. | 17749 730 |
| Base plate code | AE 16 +0.5 |
| Resulting pitch angle | +0.5° |
| Suitable for indexable insert size | 16 |
| Suitable for holder | ER/IL |

EAN-Code

4050293204308