

Approval body for construction products  
and types of construction

Bautechnisches Prüfamt

An institution established by the Federal and  
Laender Governments



## European Technical Assessment

**ETA-11/0106**  
**of 13 September 2022**

English translation prepared by DIBt - Original version in German language

### General Part

Technical Assessment Body issuing the  
European Technical Assessment:

Deutsches Institut für Bautechnik

Trade name of the construction product

REISSER screws

Product family  
to which the construction product belongs

Screws for use in timber constructions

Manufacturer

REISSER-Schraubentechnik GmbH  
Fritz-Müller-Straße 10  
74653 Ingelfingen-Criesbach  
DEUTSCHLAND

Manufacturing plant

C1230, M1222, D1030, W1239, O1209, V1430, O1603,  
E1702, F1703, J0205, P1901, P1902, P1903, P1904

This European Technical Assessment  
contains

49 pages including 5 annexes which form an integral part  
of this assessment

This European Technical Assessment is  
issued in accordance with Regulation (EU)  
No 305/2011, on the basis of

EAD 130118-01-0603 – SCREWS AND THREADED  
RODS IN TIMBER STRUCTURES

This version replaces

ETA-11/0106 issued on 1 February 2019

The European Technical Assessment is issued by the Technical Assessment Body in its official language. Translations of this European Technical Assessment in other languages shall fully correspond to the original issued document and shall be identified as such.

Communication of this European Technical Assessment, including transmission by electronic means, shall be in full. However, partial reproduction may only be made with the written consent of the issuing Technical Assessment Body. Any partial reproduction shall be identified as such.

This European Technical Assessment may be withdrawn by the issuing Technical Assessment Body, in particular pursuant to information by the Commission in accordance with Article 25(3) of Regulation (EU) No 305/2011.

**Specific Part**

**1 Technical description of the product**

REISSER R 2, RETINOX, DNS, DRIBO, SPARIBO, UHB, Vi-Port, HBS, TKS, STRONGI, fully threaded HBS screws, wooden façade screws, terrace screws and façade panels screws are screws made from special carbon or stainless steel. Screws made from carbon steel are hardened. They have a corrosion protection in accordance with Annex A.2.6. The outer thread diameter is not less than 3.0 mm and not greater than 12.0 mm. The overall length of the screws is ranging from 16 mm to 500 mm. Further dimensions are shown in Annex 5.

The washers are made from carbon steel. The dimensions of the washers are given in Annex 5. REISSER screws achieve a bending angle  $\alpha$  of at least  $45/d^{0.7} + 20$ , where d is the outer thread diameter of the screws.

**2 Specification of the intended use in accordance with the applicable European Assessment Document**

The performances given in Section 3 are only valid if the REISSER screws are used in compliance with the specifications and conditions given in Annex 1 to 4.

The verifications and assessment methods on which this European Technical Assessment is based lead to the assumption of a working life of the REISSER screws of at least 50 years. The indications given on the working life cannot be interpreted as a guarantee given by the producer, but are to be regarded only as a means for choosing the right products in relation to the expected economically reasonable working life of the works.

**3 Performance of the product and references to the methods used for its assessment**

**3.1 Mechanical resistance and stability (BWR 1)**

Essential characteristic	Performance
Dimensions	See Annex 5
Characteristic yield moment	See Annex 2
Bending angle	See Annex 2
Characteristic withdrawal parameter	See Annex 2
Characteristic head pull-through parameter	See Annex 2
Characteristic tensile strength	See Annex 2
Characteristic yield strength	See Annex 2 and 3
Characteristic torsional strength	See Annex 2
Insertion moment	See Annex 2
Spacings, end and edge distances of the screws and minimum thickness of the wood-based materials	See Annex 2
Slip modulus for mainly axially loaded screws	See Annex 2
Durability against corrosion	See Annex 2

**3.2 Safety in case of fire (BWR 2)**

Essential characteristic	Performance
Reaction to fire	Class A1

**3.3 Safety and accessibility in use (BWR 4)**

Same as BWR 1.

**4 Assessment and verification of constancy of performance (AVCP) system applied, with reference to its legal base**

In accordance with EAD No. 130118-01-0603, the applicable European legal act is: 97/176/EC.  
The system to be applied is: 3

**5 Technical details necessary for the implementation of the AVCP system, as provided for in the applicable EAD**

Technical details necessary for the implementation of the AVCP system are laid down in the control plan deposited with Deutsches Institut für Bautechnik.

Issued in Berlin on 13 September 2022 by Deutsches Institut für Bautechnik

Anja Dewitt  
Head of Section

*beglaubigt:*  
Blümel

English translation prepared by DIBt

## Annex 1 Specifications of intended use

### A.1.1 Use of the REISSER screws only for:

- Static and quasi-static loads (not relevant to fatigue)

### A.1.2 Connection materials

The screws are used for connections in load-bearing timber structures between wood-based members or between wood-based members and steel members:

- Solid timber (softwood) in accordance with EN 14081-1<sup>1</sup>,
- Glued laminated timber in accordance with EN 14080<sup>2</sup>,
- Glued solid timber in accordance with EN 14080,
- Laminated veneer lumber LVL (softwood) in accordance with EN 14374<sup>3</sup>, arrangement of the screws only perpendicular to the plane of the veneers,
- Cross laminated timber (softwood) in accordance with European Technical Assessments,
- Oriented strand boards, OSB/3 or OSB/4 in accordance with EN 300<sup>4</sup> and EN 13986<sup>5</sup> with a minimum thickness of 18 mm.

The screws are used for connecting the following wood-based panels to the timber members mentioned above:

- Oriented strand boards (OSB) in accordance with EN 300 and EN 13986,
- Plywood in accordance with EN 636<sup>6</sup> and EN 13986,
- Particleboards in accordance with EN 312<sup>7</sup> and EN 13986,
- Cement-bonded particleboards in accordance with EN 634-2<sup>8</sup> and EN 13986,
- Fibreboards in accordance with EN 622-2<sup>9</sup>, EN 622-3<sup>10</sup> and EN 13986,
- Solid wood panels (SWP) in accordance with EN 13353<sup>11</sup> and EN 13986.

Wood-based panels are only arranged on the side of the screw head, except OSB/3 and OSB/4 panels with a minimum thickness of 18 mm.

REISSER screws with an outer thread diameter  $d$  of at least 6 mm are also used for the fixing of thermal insulation material on top of rafters or on wood-based members in vertical façades.

HBS screws with  $d = 8$  mm and a full thread may be used for reinforcing of timber structures perpendicular to the grain.

1	EN 14081-1:2005+A1:2011	Timber structures – Strength graded structural timber with rectangular cross section – Part 1: General requirements
2	EN 14080:2013	Timber structures – Glued laminated timber and glued solid timber – Requirements
3	EN 14374:2004	Timber structures – Structural laminated veneer lumber – Requirements
4	EN 300:2006	Oriented strand boards (OSB) – Definition, classification and specifications
5	EN 13986:2004+A1:2015	Wood-based panels for use in construction – Characteristics, evaluation of conformity and marking
6	EN 636:2012+A1:2015	Plywood – Specifications
7	EN 312:2010	Particleboards – Specifications
8	EN 634-2:2007	Cement-bonded particleboards – Specifications – Part 2: Requirements for OPC bonded particleboards for use in dry, humid and external conditions
9	EN 622-2:2004/AC:2005	Fibreboards – Specifications – Part 2: Requirements for hardboards
10	EN 622-3:2004	Fibreboards – Specifications – Part 3: Requirements for medium boards
11	EN 13353:2022	Solid wood panels (SWP) – Requirements

REISSER screws	Annex 1.1
Specifications of intended use	

English translation prepared by DIBt

### A.1.3 Use conditions (environmental conditions)

The corrosion protection of REISSER screws is specified in Annex A.2.6.

### A.1.4 Installation provisions

EN 1995-1-1<sup>12</sup> applies for the installation of REISSER screws.

A minimum of two screws is used for connections in load-bearing timber structures.

The screws are either driven into the wood-based member made of softwood without pre-drilling or in pre-drilled holes with a diameter not exceeding the inner thread diameter  $d_1$ .

The screw holes in steel members are pre-drilled with an adequate diameter greater than the outer thread diameter.

If screws with an outer thread diameter  $d \geq 8$  mm are driven into the wood-based member without pre-drilling, the solid timber, glued laminated timber, glued solid timber, laminated veneer lumber and cross laminated timber is from spruce, pine or fir.

In the case of fastening counter battens on thermal insulation material on top of rafters the screws are driven in the rafter through the counter battens and the thermal insulation material without pre-drilling in one sequence.

Countersunk head screws may be used with washers in accordance with Annex 5. After inserting the screws the washers shall touch the surface of the wood-based member completely. Screws made from carbon steel have to be used with washers made from carbon steel and screws made from stainless steel have to be used with washers made from stainless steel.

By fastening screws in wood-based members the head of the screws is flush with the surface of the wood-based member. For pan head, half-round head, head with washer face and hexagonal head the head part remains unconsidered.

<sup>12</sup> EN 1995-1-1:2004/AC:2006  
+A1:2008+A2:2014

Eurocode 5: Design of timber structures – Part 1-1: General – Common rules and rules for buildings

REISSER screws	Annex 1.2
Installation provisions	

English translation prepared by DIBt

## Annex 2 Characteristic values of the load-carrying capacities

Table A.2.1 Characteristic load-carrying capacities of REISSER screws

Outer thread diameter d [mm]		3.0	3.5	4.0	4.2	4.5	4.8	5.0	5.5	6.0	7.0	8.0	10.0	12.0	
Characteristic yield moment $M_{y,k}$ [Nm]	Carbon steel	1.6	2.3	3.3	3.3	4.5	5.3	5.9	7.6	9.5	17.0	20.0	30.0	60.0	
	Stainless steel	0.9	1.4	1.9	1.9	2.6	3.0	3.4	4.4	5.5	-	12.0	21.0	-	
Characteristic tensile strength $f_{tens,k}$ [kN]	Carbon steel	Other screws	2.8	3.8	5.0	5.0	6.4	7.1	7.9	9.5	11.3	18.0	15.1	23.6	40.0
		HBS Full thread											20.1		
	Stainless steel	1.8	2.4	3.1	3.1	4.0	4.4	4.9	5.9	7.1	-	12.6	19.6	-	
Characteristic torsional moment $f_{tor,k}$ [Nm]	Carbon steel	Other screws	1.6	2.0	3.5	3.5	5.0	5.4	6.0	9.0	11.0	18.0	22.0	36.0	68.0
		HBS Full thread											30.0		
	Stainless steel	1.0	1.4	2.2	2.2	3.0	3.6	4.0	6.0	8.0	-	18.0	34.0	-	

### A.2.1 General

All REISSER screws achieve a bending angle  $\alpha$  of at least  $45/d^{0.7} + 20$ , where d is the outer thread diameter of the screws.

The minimum penetration length of the threaded part of the screw in the wood-based members  $l_{ef}$  is:

$$l_{ef} \geq \frac{4 \cdot d}{\sin \alpha} \quad (2.1)$$

Where

$\alpha$  angle between screw axis and grain direction [°],

d outer thread diameter of the screw [mm].

The outer thread diameter d of screws inserted in cross laminated timber is at least 6 mm. The inner thread diameter  $d_1$  of the screws used in cross laminated timber is greater than the maximal width of the gaps in the layer of cross laminated timber.

### A.2.2 Laterally loaded screws

#### A.2.2.1 General

The outer thread diameter d is used as effective diameter of the screw in accordance with EN 1995-1-1.

The embedding strength for the screws in wood-based members or in wood-based panels shall be taken from EN 1995-1-1.

REISSER screws	Annex 2.1
Characteristic values of the load-carrying capacities	

English translation prepared by DIBt

### A.2.2.2 Cross laminated timber

The embedding strength for screws arranged in the narrow faces parallel to the plane of cross laminated timber may be assumed with equation (2.2) independent of the angle between screw axis and grain direction,  $0^\circ \leq \alpha \leq 90^\circ$ :

$$f_{h,k} = 20 \cdot d^{-0,5} \quad [\text{N/mm}^2] \quad (2.2)$$

unless otherwise specified in the technical specification of the cross laminated timber.

Where  $d$  is the outer thread diameter of the screws in mm.

Equation (2.2) is only valid for softwood layers. The provisions in the European Technical Assessment of the cross laminated timber apply.

The embedding strength for screws in the wide faces of cross laminated timber shall be assumed as for solid timber based on the characteristic density of the outer layer. Where applicable, the angle between force and grain direction of the outer layer shall be considered. The direction of the lateral force shall be perpendicular to the screw axis and parallel to the wide face of the cross laminated timber.

### A.2.3 Axially loaded screws

#### A.2.3.1 Slip modulus for mainly axially loaded screws

The axial slip modulus  $K_{ser}$  of the threaded part of a screw for the serviceability limit state is taken independent of angle  $\alpha$  to the grain as:

$$K_{ser} = 780 \cdot d^{0,2} \cdot l_{ef}^{0,4} \quad [\text{N/mm}] \quad (2.3)$$

Where

$d$  outer thread diameter of the screw [mm],

$l_{ef}$  penetration length of the of the threaded part of the screw in the wood-based member [mm].

#### A.2.3.2 Axial withdrawal capacity – Characteristic withdrawal parameter

The characteristic withdrawal parameter for REISSER screws at an angle  $\alpha = 90^\circ$  to the grain based on a characteristic density of the wood-based member of  $350 \text{ kg/m}^3$  is

$f_{ax,k} = 11.0 \text{ N/mm}^2$  for all screws with  $d = 10 \text{ mm}$ , HBS screws with  $d = 8 \text{ mm}$  and UHB screws ( $d = 8 \text{ mm}$ ) and  $f_{ax,k} = 12.5 \text{ N/mm}^2$  for the remaining screws.

The characteristic withdrawal parameter is also valid for softwood layers of cross laminated timber.

For LVL a maximum characteristic density of  $500 \text{ kg/m}^3$  shall be used in equation (8.40a) of EN 1995-1-1.

For OSB/3 and OSB/4 panels the characteristic withdrawal parameter at an angle of  $\alpha = 90^\circ$  to the plane based on a characteristic density of the OSB panel of  $600 \text{ kg/m}^3$  is

$f_{ax,k} = 10.0 \text{ N/mm}^2$  for DRIBO and SPARIBO screws with  $4 \text{ mm} \leq d \leq 6 \text{ mm}$ .

The minimum thickness of the OSB panel is 18 mm.

For screws penetrating more than one layer of cross laminated timber the different layers may be taken into account proportionally. In the narrow faces of the cross laminated timber the screws are fully inserted in one layer of cross laminated timber.

REISSER screws	Annex 2.2
Characteristic values of the load-carrying capacities	



English translation prepared by DIBt

The characteristic axial withdrawal capacity for screws arranged parallel to the wide faces of cross laminated timber, independent of the angle between screw axis and grain direction,  $30^\circ \leq \alpha \leq 90^\circ$ , may be calculated as:

$$F_{ax,Rk} = 20 \cdot d^{0,8} \cdot l_{ef}^{0,9} \quad [N] \quad (2.4)$$

Where

d outer thread diameter of the screw [mm],

$l_{ef}$  penetration length of the threaded part of the screw in the cross laminated timber [mm].

### A.2.3.3 Head pull-through capacity – Characteristic head pull-through parameter

The characteristic value of the head pull-through parameter for REISSER screws for a characteristic density of  $350 \text{ kg/m}^3$  of the timber and for wood-based panels like

- Oriented strand boards (OSB) in accordance with EN 300 and EN 13986,
- Plywood in accordance with EN 636 and EN 13986,
- Particleboards in accordance with EN 312 and EN 13986,
- Cement-bonded particleboards in accordance with EN 634-2 and EN 13986,
- Fibreboards in accordance with EN 622-2, EN 622-3 and EN 13986,
- Solid wood panels (SWP) in accordance with EN 13353 and EN 13986,

with a thickness of more than 20 mm is

$$f_{head,k} = 9.4 \text{ N/mm}^2.$$

For LVL maximum characteristic density of  $500 \text{ kg/m}^3$  shall be used in equation (8.40b) of EN 1995-1-1, for wood-based panels a maximum characteristic density of  $380 \text{ kg/m}^3$ .

The head diameter shall be equal to or greater than  $1.8 \cdot d_s$ , where  $d_s$  is the smooth shank or the inner thread diameter. Otherwise the characteristic head pull-through capacity in equation (8.40b) is  $F_{ax,\alpha,Rk} = 0$  for all wood-based materials.

For wood-based panels with a thickness  $12 \text{ mm} \leq t \leq 20 \text{ mm}$  the characteristic value of the head pull-through parameter for REISSER screws is:

$$f_{head,k} = 8.0 \text{ N/mm}^2.$$

For wood-based panels with a thickness of less than 12 mm the characteristic head pull-through capacity for screws shall be based on a characteristic value of the head pull-through parameter of  $8.0 \text{ N/mm}^2$ . The characteristic head pull-through capacity shall be limited to 400 N. A minimum thickness of the wood-based panels of  $1.2 \cdot d$ , where  $d$  is the outer thread diameter, and the values in Table A.2.2 shall be complied.

Table A.2.2 Minimum thickness of wood-based panels

Wood-based panel	Minimum thickness [mm]
Plywood	6
Fibreboards (hardboards and medium boards)	6
Oriented strand boards (OSB)	8
Particleboards	8
Cement-bonded particleboards	8
Solid wood panels (SWP)	12

Outer diameter of washer  $d_k > 32 \text{ mm}$  shall not be considered.

In steel-to-timber connections the head pull-through capacity is not governing.

REISSER screws	Annex 2.3
Characteristic values of the load-carrying capacities	

English translation prepared by DIBt

#### A.2.3.4 Compressive capacity of fully threaded HBS screws with $d = 8$ mm – Characteristic yield strength

The design axial compressive capacity  $F_{ax,Rd}$  of HBS screws with  $d = 8$  mm and a full thread embedded in solid timber, glued solid timber or glued laminated timber made from softwood with an angle  $\alpha$  between screw axis and grain direction of  $30^\circ \leq \alpha \leq 90^\circ$  is the minimum of the axial resistance against pushing-in and the buckling resistance of the screw.

$$F_{ax,Rd} = \min \{ f_{ax,d} \cdot d \cdot l_{ef}; \kappa_c \cdot N_{pl,d} \} \quad (2.5)$$

$f_{ax,d}$  design value of the axial withdrawal parameter of the threaded part of the screw [N/mm<sup>2</sup>],

$d$  outer thread diameter of the screw [mm],

$l_{ef}$  penetration length of the threaded part of the screw in the timber member [mm].

$$\kappa_c = 1 \quad \text{für } \bar{\lambda}_k \leq 0,2 \quad (2.6)$$

$$\kappa_c = \frac{1}{k + \sqrt{k^2 - \bar{\lambda}_k^2}} \quad \text{für } \bar{\lambda}_k > 0,2 \quad (2.7)$$

$$k = 0,5 \cdot \left[ 1 + 0,49 \cdot (\bar{\lambda}_k - 0,2) + \bar{\lambda}_k^2 \right] \quad (2.8)$$

and a relative slenderness ratio  $\bar{\lambda}_k = \sqrt{\frac{N_{pl,k}}{N_{ki,k}}}$  (2.9)

$N_{pl,k}$  characteristic plastic normal force related to the net cross section of the inner thread diameter:

$$N_{pl,k} = \pi \cdot \frac{d_1^2}{4} \cdot f_{y,k} \quad (2.10)$$

$f_{y,k}$  characteristic yield strength,  $f_{y,k} = 1000$  N/mm<sup>2</sup> for fully threaded HBS screws with  $d = 8$  mm,

$d_1$  inner thread diameter of the screw [mm].

$$N_{pl,d} = \frac{N_{pl,k}}{\gamma_{M1}} \quad (2.11)$$

$\gamma_{M1}$  partial factor in accordance with EN 1993-1-1.

characteristic ideal elastic buckling load:

$$N_{ki,k} = \sqrt{c_h \cdot E_s \cdot I_s} \quad [N] \quad (2.12)$$

elastic foundation of the screw:

$$c_h = (0,19 + 0,012 \cdot d) \cdot \rho_k \cdot \left( \frac{90^\circ + \alpha}{180^\circ} \right) \quad [N/mm^2] \quad (2.13)$$

$\rho_k$  characteristic density of the wood-based member [kg/m<sup>3</sup>], for LVL  $\leq 500$  kg/m<sup>3</sup>,

$\alpha$  angle between screw axis and grain direction,  $30^\circ \leq \alpha \leq 90^\circ$ ,

modulus of elasticity:  $E_s = 210000$  N/mm<sup>2</sup>, second moment of area:  $I_s = \frac{\pi \cdot d_1^4}{64}$  [mm<sup>4</sup>]. (2.14)

REISSER screws	Annex 2.4
Compressiv capacity – Characteristic yield strength	

English translation prepared by DIBt

## A.2.4 Spacings, end and edge distances of the screws and minimum thickness of the wood-based material

### A.2.4.1 Laterally or laterally *and* axially loaded screws

#### **Screws in pre-drilled holes**

For REISSER screws in pre-drilled holes the minimum spacings, end and edge distances are given in EN 1995-1-1, clause 8.3.1.2 and Table 8.2 as for nails in pre-drilled holes. Here, the outer thread diameter  $d$  shall be considered. Minimum thickness for structural members made of solid timber, glued laminated timber, glued solid timber, laminated veneer lumber and cross laminated timber is  $t = 30$  mm for screws with  $d \leq 8$  mm,  $t = 40$  mm for screws with  $d = 10$  mm and  $t = 80$  mm for screws with  $d = 12$  mm.

#### **Screws in non pre-drilled holes**

For REISSER screws in non-predrilled holes the minimum spacings, end and edge distances as well as the minimum member thicknesses are given in EN 1995-1-1, clause 8.3.1.2 and Table 8.2 as for nails in non-predrilled holes. Here, the outer thread diameter  $d$  shall be considered.

For Douglas fir members minimum spacings and distances parallel to the grain shall be increased by 50 %.

Minimum distances from loaded or unloaded ends parallel to the grain shall be at least  $15 \cdot d$  for screws with outer thread diameter  $d > 8$  mm and timber thickness  $t < 5 \cdot d$ .

Minimum distances from the unloaded edge perpendicular to the grain may be reduced to  $3 \cdot d$  also for timber thickness  $t < 5 \cdot d$ , if the spacing parallel to the grain and the end distance is at least  $25 \cdot d$ .

REISSER screws	Annex 2.5
Spacings, end and edge distances and dimensions	

English translation prepared by DIBt

#### A.2.4.2 Only axially loaded screws

For SPARIBO screws with  $d = 6$  mm and HBS screws with  $d = 8$  mm and a full thread loaded only axially the minimum spacings, end and edge distances given in Table A.2.3 or those given in paragraph A.2.4.1 apply for solid timber, glued laminated timber and similar glued products made from softwood.

Table A.2.3 Minimum spacings, end and edge distances of the screws and minimum thickness and width of the timber

Screw type	SPARIBO	HBS
Outer thread diameter $d$ [mm]	6	8
Minimum spacing $a_1$ in a plane parallel to grain	$5 \cdot d$	$5 \cdot d$
Minimum spacing $a_2$ perpendicular to a plane parallel to grain	$4 \cdot d$	$2.5 \cdot d$
Minimum end distance of the centre of gravity of the threaded part in the timber member $a_{1,c}$	$10 \cdot d$	$10 \cdot d$
Minimum edge distance of the centre of gravity of the threaded part in the timber member $a_{2,c}$	$2.5 \cdot d$	$4 \cdot d$
Minimum product of spacing $a_1$ and $a_2$	$a_1 \cdot a_2 = 25 \cdot d^2$	$a_1 \cdot a_2 = 25 \cdot d^2$
Crossed screw couples – Minimum spacing between the crossing screws <sup>13</sup>	$1.5 \cdot d$	$1.5 \cdot d$
Minimum timber thickness	$10 \cdot d$	$10 \cdot d$
Minimum timber width	$5 \cdot d$	$\max \begin{cases} 8 \cdot d \\ 60 \text{ mm} \end{cases}$

For the verification of resistance in accordance with EN 1995-1-1, clause 8.7.2 (1) the failure along the circumference of a group of screws has to be considered also for connections without steel plates, if the spacings, end and edge distances are less than the distances and thicknesses given in EN 1995-1-1.

<sup>13</sup> Appropriate means have to ensure that the crossed screw threads do not touch each other when being inserted in the timber member.

REISSER screws	Annex 2.6
Spacings, end and edge distances and dimensions	

English translation prepared by DIBt

### A.2.4.3 Cross laminated timber

The minimum requirements for spacings, end and edge distances of screws in the wide and narrow faces of cross laminated timber are summarised in Table A.2.4. The definitions of spacings, end and edge distances are shown in Figure A.2.1 and Figure A.2.2. The minimum spacings, end and edge distances in the narrow faces are independent of the angle between screw axis and grain direction. They shall be used based on the following conditions:

- minimum thickness of cross laminated timber:  $10 \cdot d$
- minimum penetration depth of the screws in the narrow faces of the cross laminated timber:  $10 \cdot d$

Table A.2.4 Minimum spacings, end and edge distances of screws in the wide or narrow faces of cross laminated timber

	$a_1$	$a_{3,t}$	$a_{3,c}$	$a_2$	$a_{4,t}$	$a_{4,c}$
Wide faces (see Figure A.2.1)	$4 \cdot d$	$6 \cdot d$	$6 \cdot d$	$2.5 \cdot d$	$6 \cdot d$	$2.5 \cdot d$
Narrow faces (see Figure A.2.2)	$10 \cdot d$	$12 \cdot d$	$7 \cdot d$	$4 \cdot d$	$6 \cdot d$	$3 \cdot d$

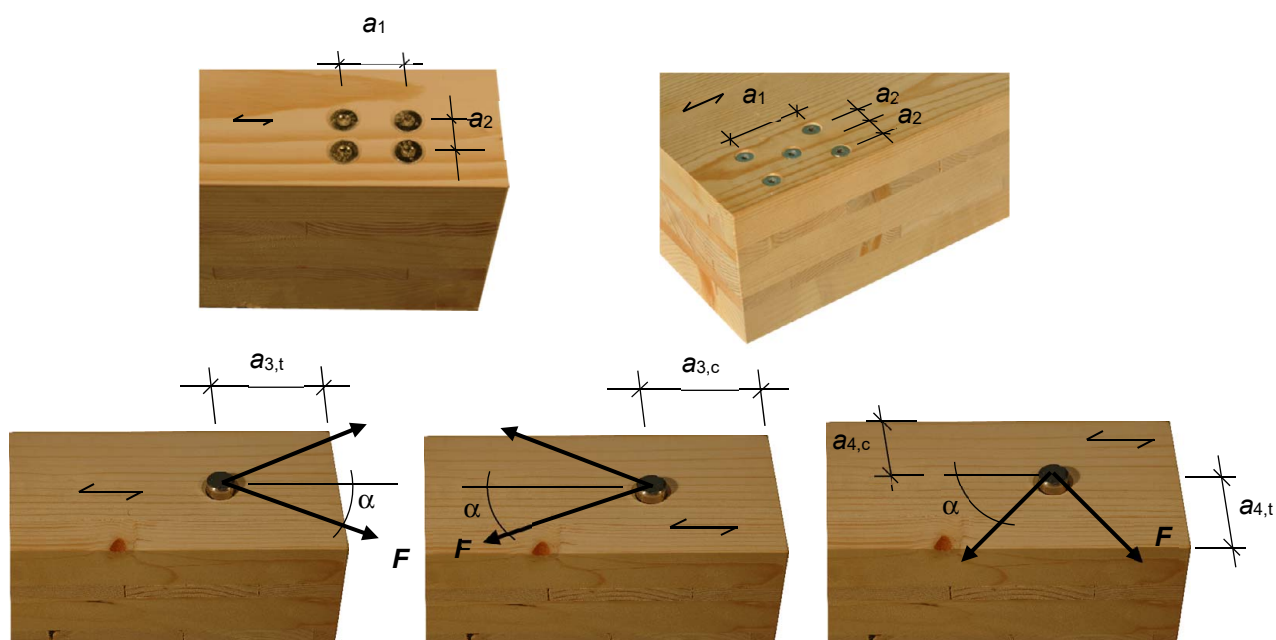

Figure A.2.1 Definition of spacings, end and edge distances in the wide faces

REISSER screws	Annex 2.7
Spacings, end and edge distances and dimensions	

English translation prepared by DIBt

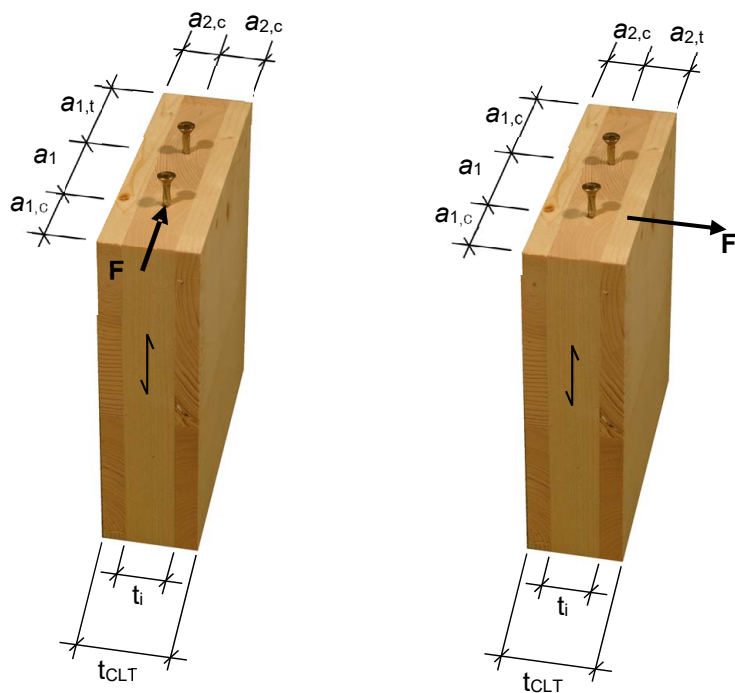
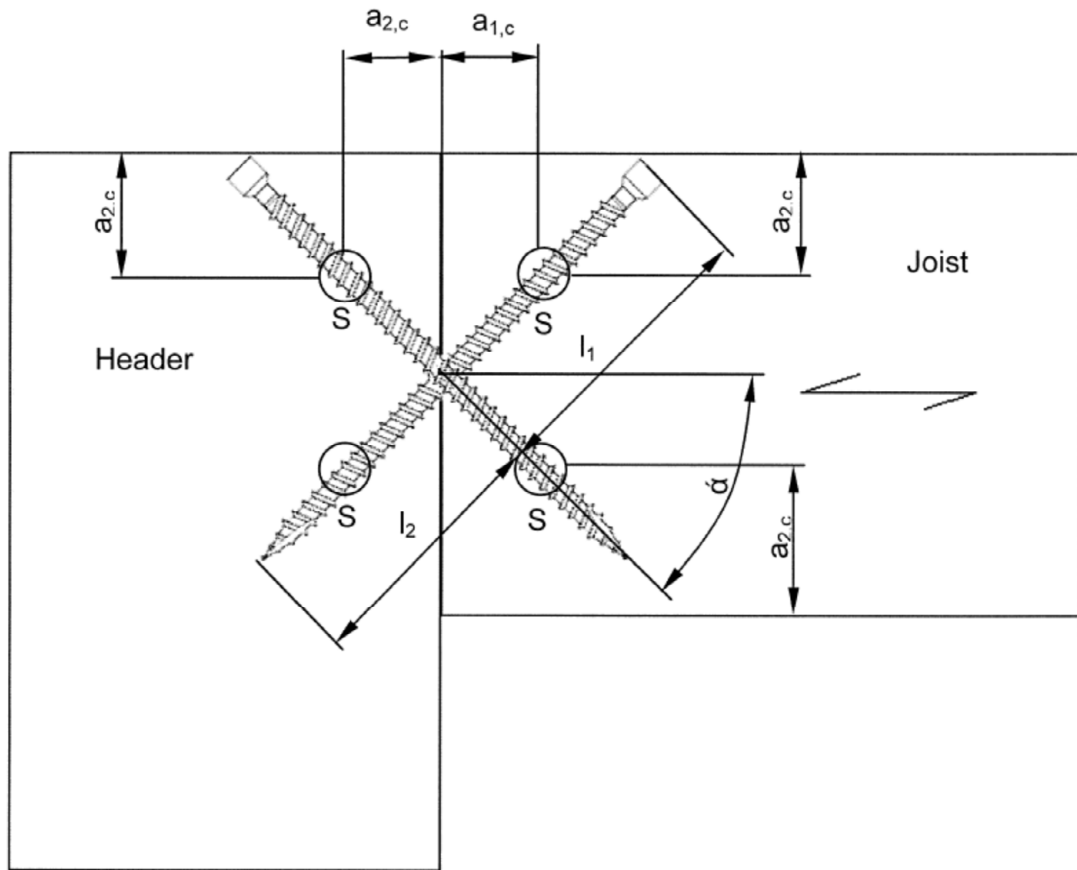

Figure A.2.2 Definition of spacings, end and edge distances in the narrow faces

REISSER Schrauben	Annex 2.8
Spacings, end and edge distances and dimensions	

English translation prepared by DIBt

**Examples of use for HBS screws with  $d = 8$  mm and a full thread**  
**Header-joist connection**



S Centroid of the part of the screw in the timber

REISSER screws	Annex 2.9
Use examples	

English translation prepared by DIBt

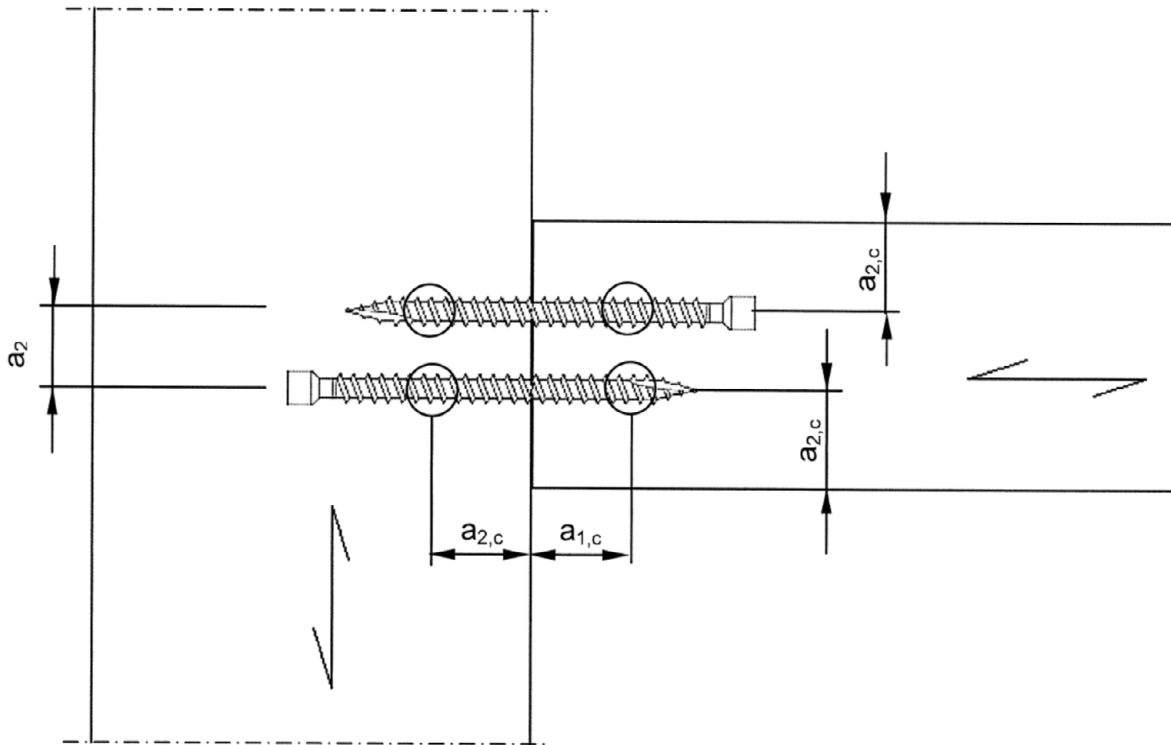

REISSER screws	Annex 2.10
Use examples	



English translation prepared by DIBt

**Parallel inclined screws to connect wood-based members**

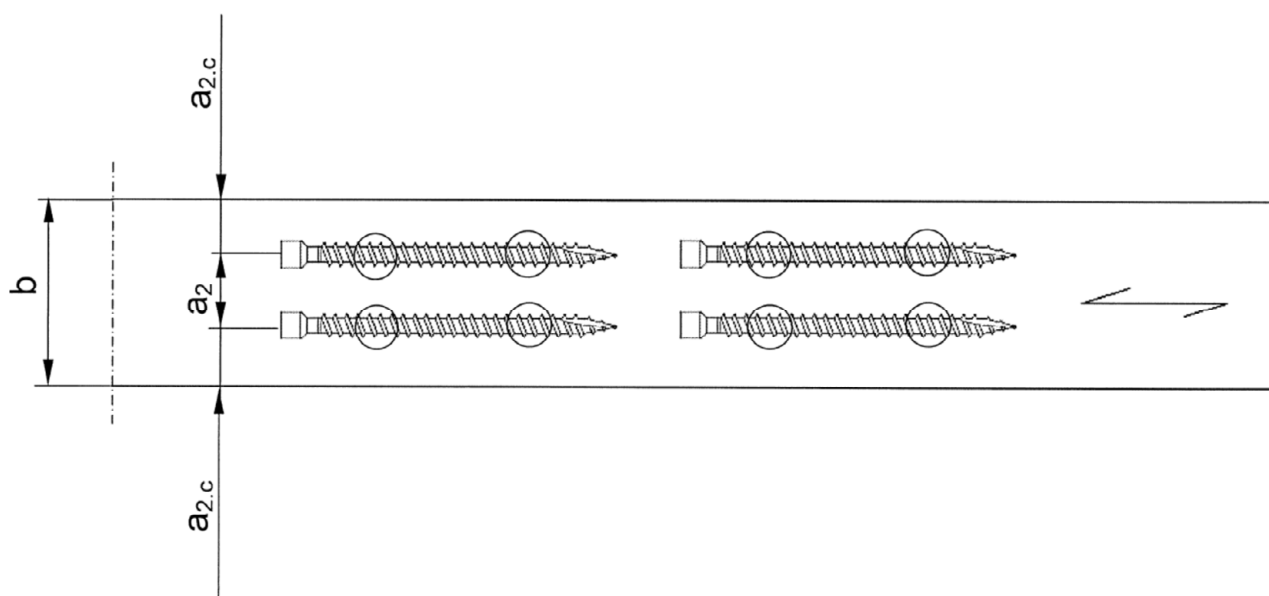
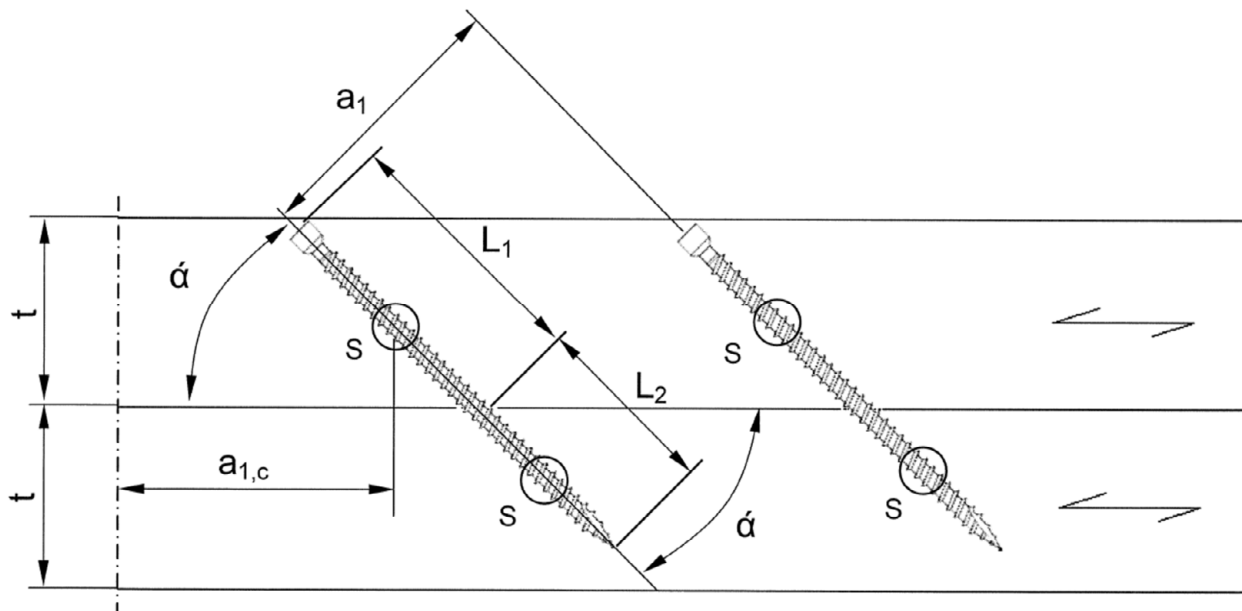

- S Centroid of the part of the screw in the timber
- t Thickness of the wood-based member
- b Width of the wood-based member

REISSER screws	Annex 2.11
Use examples	

English translation prepared by DIBt

### A.2.5 Insertion moment

The ratio between the characteristic torsional strength  $f_{tor,k}$  and the mean value of insertion moment  $R_{tor,mean}$  fulfills the requirement for all screws.

### A.2.6 Durability against corrosion

Screws made from carbon steel are electrolytically galvanised and yellow or blue chromated/ passivated. Alternatively, a zinc flake coating (Duplex- or Base/ Top Coat treatment) is used. The base coating is a Zn-Ni layer, on which a zinc layer (Duplex treatment) or an organic layer (Base/ Top Coat treatment) is applied. The mean thickness of the zinc coating of the screws is 5 - 8  $\mu\text{m}$ .

Steel no. 1.4301 (A2), 1.4567 (A2), 1.4401 (A4), 1.4578 (A4), 1.4539 (A5) or 1.4529 (A8) are used for screws made from stainless steel.

REISSER screws	Annex 2.12
Insertion moment and durability against corrosion	

English translation prepared by DIBt

## Annex 3 Compression reinforcement perpendicular to the grain

### A.3.1 General

Only HBS screws with  $d = 8$  mm and a full thread may be used for compression reinforcement perpendicular to the grain. The provisions are valid for reinforcing timber members made from solid timber, glued solid timber or glued laminated timber made from softwood.

The compression force shall be distributed evenly to the screws used as compression reinforcement.

The screws are driven into the timber member perpendicular to the contact surface under an angle between the screw axis and the grain direction of  $45^\circ$  to  $90^\circ$ . The screw heads shall be flush with the timber surface.

### A.3.2 Design

For the design of reinforced contact areas the following conditions shall be met independent of the angle between the screw axis and the grain direction.

The design resistance of a reinforced contact area is:

$$R_{90,d} = \min \left\{ \begin{array}{l} k_{c,90} \cdot B \cdot \ell_{ef,1} \cdot f_{c,90,d} + n \cdot \min \{ R_{ax,d}; \kappa_c \cdot N_{pl,d} \} \\ B \cdot \ell_{ef,2} \cdot f_{c,90,d} \end{array} \right\} \quad (3.1)$$

Where

$k_{c,90}$  parameter in accordance with EN 1995-1-1, clause 6.1.5,

$B$  bearing width [mm],

$\ell_{ef,1}$  effective contact length in accordance with EN 1995-1-1, clause 6.1.5 [mm],

$f_{c,90,d}$  design compressive strength perpendicular to the grain [ $N/mm^2$ ],

$n$  number of reinforcing screws,  $n = n_0 \cdot n_{90}$ ,

$n_0$  number of reinforcing screws arranged in a row parallel to the grain,

$n_{90}$  number of reinforcing screws arranged in a row perpendicular to the grain,

$$R_{ax,d} = f_{ax,d} \cdot d \cdot \ell_{ef} \quad [N], \quad (3.2)$$

$f_{ax,d}$  design value of the withdrawal parameter of the threaded part of the screw [ $N/mm^2$ ],

$d$  outer thread diameter of the screw [mm],

$$\kappa_c \cdot N_{pl,d} = \frac{\kappa_c \cdot N_{pl,k}}{\gamma_{M1}} \quad \text{with } \kappa_c \cdot N_{pl,k} \text{ in accordance with Table A.3.1 [N]}, \quad (3.3)$$

$\ell_{ef,2}$  effective contact length in the plane of the screw tips (see Figure A.3.1) [mm],

$\ell_{ef,2} = \{ \ell_{ef} + (n_0 - 1) \cdot a_1 + \min(\ell_{ef}; a_{1,c}) \}$  for end supports (see Figure A.3.1 left),

$\ell_{ef,2} = \{ 2 \cdot \ell_{ef} + (n_0 - 1) \cdot a_1 \}$  for intermediate supports (see Figure A.3.1 right),

$\ell_{ef}$  threaded length of the screw in the timber member [mm],

$\gamma_{M1}$  partial factor in accordance with EN 1993-1-1<sup>14</sup>.

<sup>14</sup> EN 1993-1-1:2005/AC:2009 Eurocode 3: Design of steel structures – Part 1-1: General rules and rules for buildings +A1:2014

REISSER screws	Annex 3.1
Compression reinforcement perpendicular to the grain	

English translation prepared by DIBt

Table A.3.1 Characteristic load-carrying capacity  $K_C \cdot N_{pl,k}$  for fully threaded HBS screws in N

$\rho_k$ [kg/m <sup>3</sup> ]	d [mm]
	8.0
310	11800
350	12200
380	12500
410	12700
450	13000

The characteristic load-carrying capacity  $K_C \cdot N_{pl,k}$  are based on a characteristic yield strength of the HBS screws of  $f_{y,k} = 1000 \text{ N/mm}^2$ .

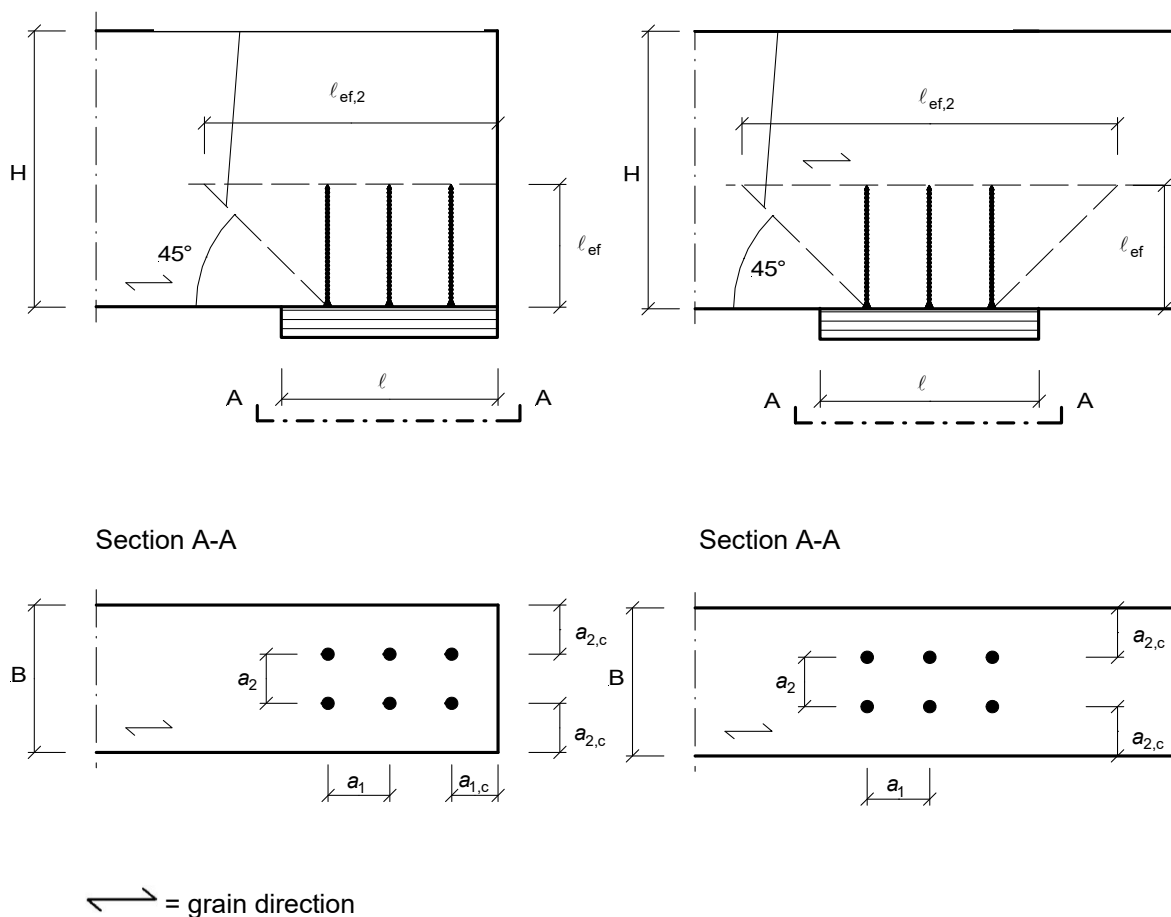

Figure A.3.1 Reinforced end support (left) and reinforced intermediate support (right)

REISSER screws	Annex 3.2
Compression reinforcement perpendicular to the grain	

English translation prepared by DIBt

## Annex 4 Fastening of thermal insulation material on top of rafters

### A.4.1 General

REISSER screws with an outer thread diameter  $d$  of at least 6 mm may be used for the fixing of thermal insulation material on top of rafters or on wood-based members in vertical façades. In the following, the meaning of the word rafter includes wood-based members with inclinations between  $0^\circ$  and  $90^\circ$ .

The thickness of the thermal insulation material is up to 400 mm. The thermal insulation material is used that is applicable as insulation on top of rafters or on wood-based members in vertical façades.

The counter battens are from solid timber in accordance with EN 14081-1. The minimum thickness  $t$  and the minimum width  $b$  of the counter battens are given in Table A.4.1:

Table A.4.1 Minimum thickness and minimum width of the counter battens

Outer thread diameter $d$ [mm]	Minimum thickness $t$ [mm]	Minimum width $b$ [mm]
6 and 8	30	50
10	40	60
12	80	100

The minimum width of the rafters is 60 mm.

The spacing between screws  $e_s$  is not more than 1.75 m.

Friction forces are not considered for the design of the characteristic axial withdrawal capacity of the screws.

The anchorage of wind suction forces of the counter battens shall be considered for design. Screws perpendicular to the grain of the rafter may be arranged where required.

### A.4.2 Parallel inclined screws and thermal insulation material in compression

#### A.4.2.1 Mechanical model

The system of rafter, thermal insulation material on top of rafter and counter battens parallel to the rafter can be considered as a beam on elastic foundation. The counter batten represents the beam, and the thermal insulation material on top of the rafter the elastic foundation. The minimum compressive stress of the thermal insulation material at 10 % deformation, measured in accordance with EN 826<sup>15</sup>, shall be  $\sigma_{10\%} = 0.05 \text{ N/mm}^2$ . The counter batten is loaded perpendicular to the axis by point loads  $F_b$ . Further point loads  $F_s$  are caused by the shear load of the roof due to dead and snow load, which are transferred from the screw heads into the counter battens.

<sup>15</sup> EN 826:2013 Thermal insulating products for building applications – Determination of compression behaviour

REISSER screws	Annex 4.1
Fastening of thermal insulation material on top of rafters	

English translation prepared by DIBt

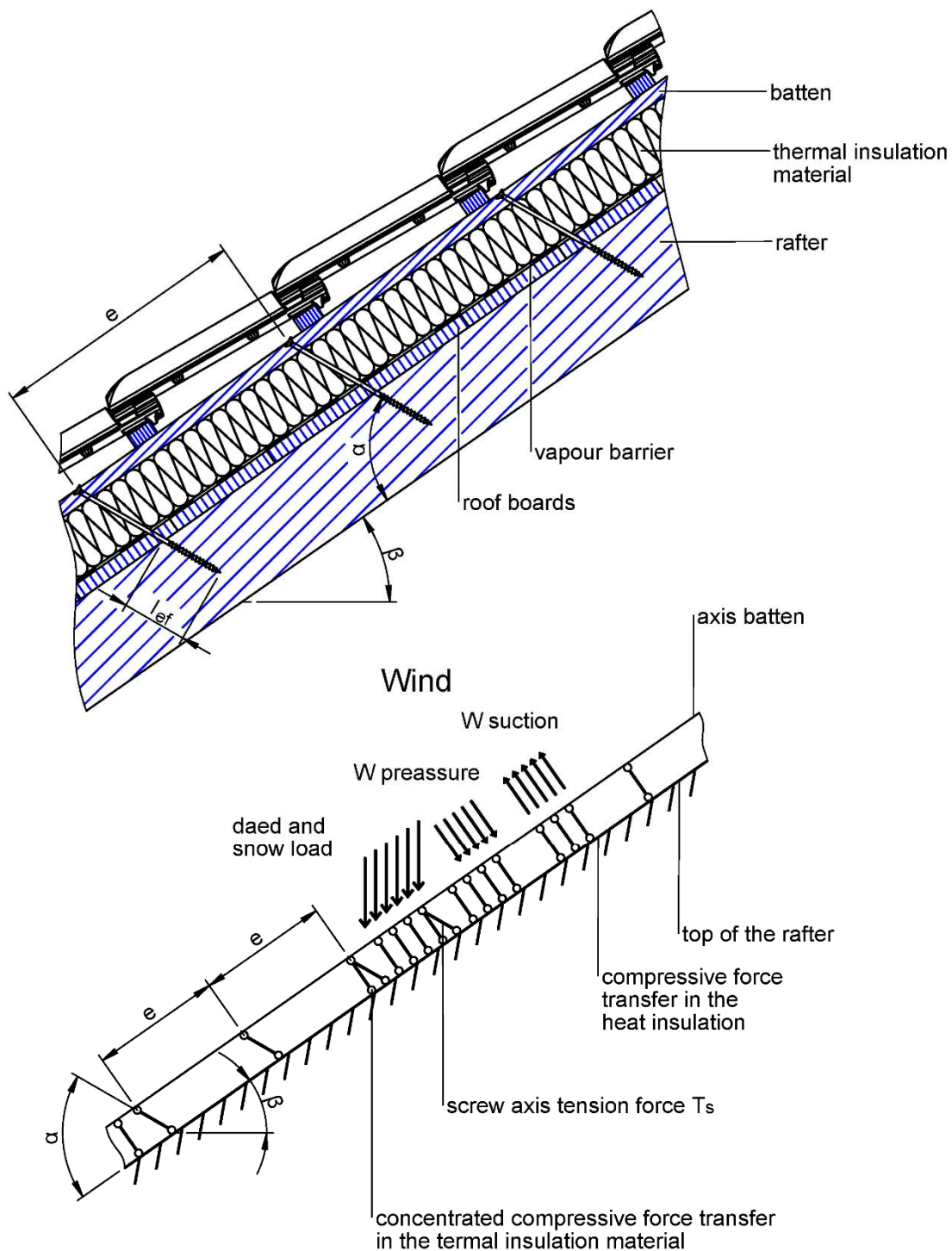

Figure A.4.1 Fastening of the thermal insulation material on top of rafters – Structural system of parallel arranged screws

REISSER screws	Annex 4.2
Fastening of thermal insulation material on top of rafters	

English translation prepared by DIBt

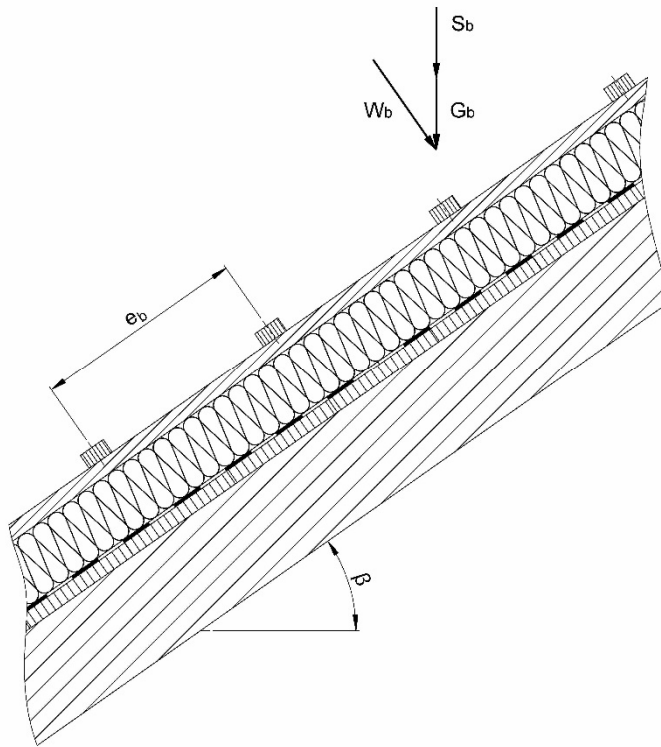

Figure A.4.2 Point loads  $F_b$  perpendicular to the counter battens

REISSER screws	Annex 4.3
Fastening of thermal insulation material on top of rafters	

English translation prepared by DIBt

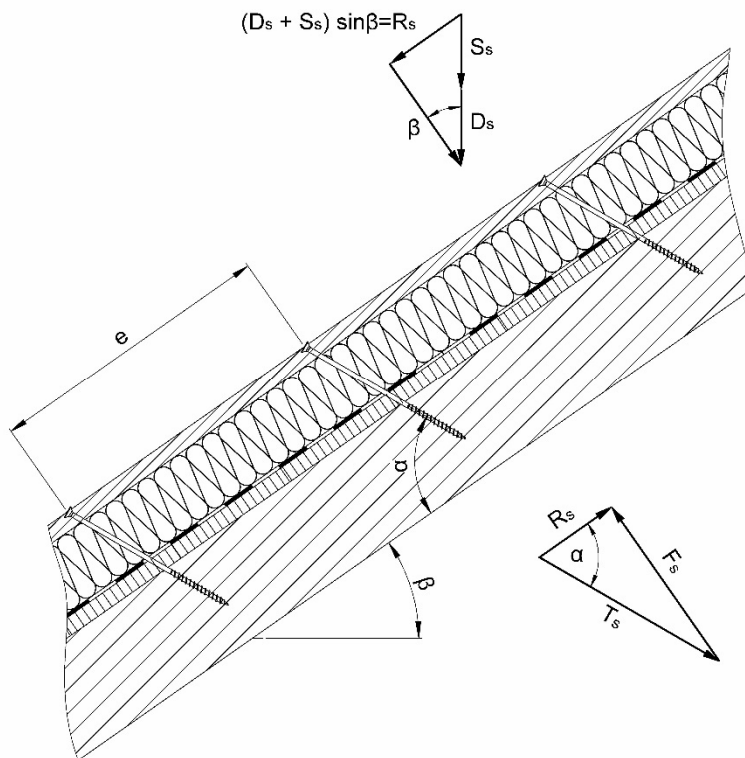

Figure A.4.3 Point loads  $F_s$  perpendicular to the counter battens, load application in the area of the screw heads

REISSER screws	Annex 4.4
Fastening of thermal insulation material on top of rafters	



English translation prepared by DIBt

#### A.4.2.2 Design of the counter battens

It is assumed that the spacing between the counter battens exceeds the characteristic length  $l_{char}$ . The characteristic values of the bending stresses may be calculated as:

$$M_k = \frac{(F_{b,k} + F_{s,k}) \cdot l_{char}}{4} \quad (4.1)$$

Where

$$l_{char} \quad \text{characteristic length } l_{char} = 4 \sqrt{\frac{4 \cdot EI}{w_{ef} \cdot K}} \quad (4.2)$$

$EI$  bending stiffness of the counter batten,

$K$  modulus of subgrade reaction,

$w_{ef}$  effective width of the thermal insulation material,

$F_{b,k}$  point loads perpendicular to the counter battens,

$F_{s,k}$  point loads perpendicular to the counter battens, load application in the area of the screw heads.

The modulus of subgrade reaction  $K$  may be calculated from the modulus of elasticity  $E_{HI}$  and the thickness  $t_{HI}$  of the thermal insulation material if the effective width  $w_{ef}$  of the thermal insulation material under compression is known. Due to the load extension in the thermal insulation material the effective width  $w_{ef}$  is greater than the width of the counter batten or rafter, respectively. For further calculations, the effective width  $w_{ef}$  of the thermal insulation material may be determined as:

$$w_{ef} = w + t_{HI} / 2 \quad (4.3)$$

Where

$w$  minimum from width of the counter batten or rafter, respectively,

$t_{HI}$  thickness of the thermal insulation material.

$$K = \frac{E_{HI}}{t_{HI}} \quad (4.4)$$

The following condition shall be satisfied:

$$\frac{\sigma_{m,d}}{f_{m,d}} = \frac{M_d}{W \cdot f_{m,d}} \leq 1 \quad (4.5)$$

For the calculation of the section modulus  $W$  the net cross section shall be considered.

The characteristic values of the shear stresses shall be calculated in accordance with:

$$V_k = \frac{(F_{b,k} + F_{s,k})}{2} \quad (4.6)$$

The following condition shall be satisfied:

$$\frac{\tau_d}{f_{v,d}} = \frac{1.5 \cdot V_d}{A \cdot f_{v,d}} \leq 1 \quad (4.7)$$

For the calculation of the cross section area the net cross section shall be considered.

REISSER screws	Annex 4.5
Fastening of thermal insulation material on top of rafters	

English translation prepared by DIBt

#### A.4.2.3 Design of the thermal insulation material

The characteristic value of the compressive stress in the thermal insulation material may be calculated as:

$$\sigma_k = \frac{1.5 \cdot F_{b,k} + F_{s,k}}{2 \cdot l_{\text{char}} \cdot w} \quad (4.8)$$

The design value of the compressive stress shall not be greater than 110 % of the compressive strength at 10 % deformation calculated in accordance with EN 826.

#### A.4.2.4 Design of the screws

The screws are loaded predominantly axial. The characteristic value of the axial tension force in the screw may be calculated from the shear loads of the roof  $R_s$ :

$$T_{S,k} = \frac{R_{S,k}}{\cos \alpha} \quad (4.9)$$

The load-carrying capacity of axially loaded screws is the minimum design value of the axial withdrawal capacity of the threaded part of the screw, the head pull-through capacity of the screw and the tensile capacity of the screw in accordance with Annex 2.

In order to limit the deformation of the screw head for thermal insulation material with thickness over 220 mm or with compressive strength below 0.12 N/mm<sup>2</sup>, respectively, the axial withdrawal capacity of the screws shall be reduced by the factors  $k_1$  and  $k_2$ :

$$F_{ax,\alpha,Rd} = \min \left\{ \frac{f_{ax,d} \cdot d \cdot l_{ef} \cdot k_1 \cdot k_2}{1.2 \cdot \cos^2 \alpha + \sin^2 \alpha} \cdot \left( \frac{\rho_k}{350} \right)^{0.8}; f_{head,d} \cdot d_h^2 \cdot \left( \frac{\rho_k}{350} \right)^{0.8}; \frac{f_{tens,k}}{\gamma_{M2}} \right\} \quad (4.10)$$

Where

$f_{ax,d}$	design value of the withdrawal parameter of the threaded part of the screw [N/mm <sup>2</sup> ],
$d$	outer thread diameter of the screw [mm],
$l_{ef}$	penetration length of the threaded part of the screw in the rafter [mm], $l_{ef} \geq 40$ mm,
$\rho_k$	characteristic density of the wood-based member [kg/m <sup>3</sup> ], for LVL the assumed characteristic density shall not exceed 500 kg/m <sup>3</sup> ,
$\alpha$	angle $\alpha$ between screw axis and grain direction, $30^\circ \leq \alpha \leq 90^\circ$ ,
$f_{head,d}$	design value of the head pull-through parameter of the screw [N/mm <sup>2</sup> ],
$d_h$	head diameter of the screw [mm],
$f_{tens,k}$	characteristic tensile capacity of the screw in accordance with Annex 2 [N],
$\gamma_{M2}$	partial factor in accordance with EN 1993-1-1,
$k_1$	$\min \{1; 220/t_{HI}\}$ ,
$k_2$	$\min \{1; \sigma_{10\%}/0.12\}$ ,
$t_{HI}$	thickness of the thermal insulation material [mm],
$\sigma_{10\%}$	compressive stress of the thermal insulation material under 10 % deformation [N/mm <sup>2</sup> ].

If equation (4.10) is fulfilled, the deflection of the counter battens does not need to be considered when designing the load-carrying capacity of the screws.

REISSER screws	Annex 4.6
Fastening of thermal insulation material on top of rafters	

English translation prepared by DIBt

### A.4.3 Alternatively inclined screws and thermal insulation material not in compression

#### A.4.3.1 Mechanical model

Depending on the screw spacing and the arrangement of tensile and compressive screws with different inclinations the counter battens are loaded by significant bending moments. The bending moments are derived based on the following assumptions:

- The tensile and compressive loads in the screws are determined based on equilibrium conditions from the actions parallel and perpendicular to the roof plane. These actions are constant line loads  $q_{\perp}$  and  $q_{\parallel}$ .
- The screws act as hinged columns supported 10 mm within the counter batten or rafter, respectively. The effective column length consequently equals the length of the screw between counter batten and rafter plus 20 mm.
- The counter batten is considered as a continuous beam with a constant span  $\ell = A + B$ . The compressive screws constitute the supports of the continuous beam while the tensile screws transfer concentrated loads perpendicular to the counter batten axis.

The screws are predominantly loaded in withdrawal or compression, respectively. The characteristic values of the screw's normal forces are determined based on the loads parallel and perpendicular to the roof plane:

$$\text{Compressive screw: } N_{c,k} = (A + B) \cdot \left( -\frac{q_{\parallel,k}}{\cos \alpha_1 + \sin \alpha_1 / \tan \alpha_2} - \frac{q_{\perp,k} \cdot \sin(90^\circ - \alpha_2)}{\sin(\alpha_1 + \alpha_2)} \right) \quad (4.11)$$

$$\text{Tensile screw: } N_{t,k} = (A + B) \cdot \left( \frac{q_{\parallel,k}}{\cos \alpha_2 + \sin \alpha_2 / \tan \alpha_1} - \frac{q_{\perp,k} \cdot \sin(90^\circ - \alpha_1)}{\sin(\alpha_1 + \alpha_2)} \right) \quad (4.12)$$

A, B distances of the screws in accordance with Figure A.4.5,

$q_{\parallel,k}$  characteristic value of the loads parallel to the roof plane,

$q_{\perp,k}$  characteristic value of the loads perpendicular to the roof plane,

$\alpha$  angle  $\alpha_1$  and  $\alpha_2$  between screw axis and grain direction,  $30^\circ \leq \alpha_1 \leq 90^\circ$ ,  $30^\circ \leq \alpha_2 \leq 90^\circ$ .

Only screws with full thread or thread under head are used.

The bending moments in the counter batten follow from the constant line load  $q_{\perp}$  and the load components perpendicular to the counter batten from the tensile screws. The span of the continuous beam is  $(A + B)$ . The characteristic value of the load component perpendicular to the counter batten from the tensile screw is:

$$F_{ZS,k} = (A + B) \cdot \left( \frac{q_{\parallel,k}}{1/\tan \alpha_1 + 1/\tan \alpha_2} - \frac{q_{\perp,k} \cdot \sin(90^\circ - \alpha_1) \cdot \sin \alpha_2}{\sin(\alpha_1 + \alpha_2)} \right) \quad (4.13)$$

A positive value for  $F_{ZS,k}$  means a load towards the rafter, a negative value a load away from the rafter. The system of the continuous beam is shown in Figure A.4.5.

The counter battens fixed on the rafter shall be supported perpendicular to the load-bearing plane.

REISSER screws	Annex 4.7
Fastening of thermal insulation material on top of rafters	

English translation prepared by DIBt

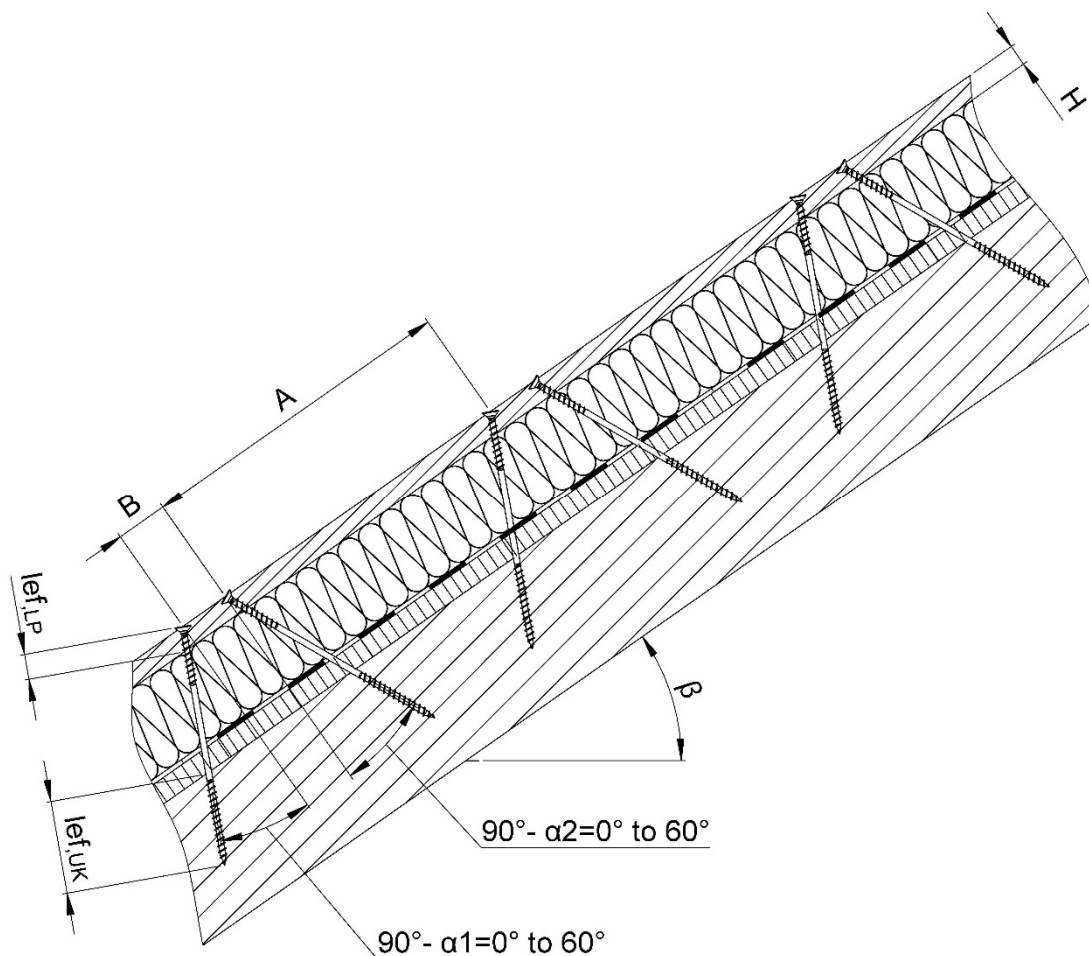

Figure A.4.4 Fastening of thermal insulation material on top of rafters – Structural system for alternatively inclined screws

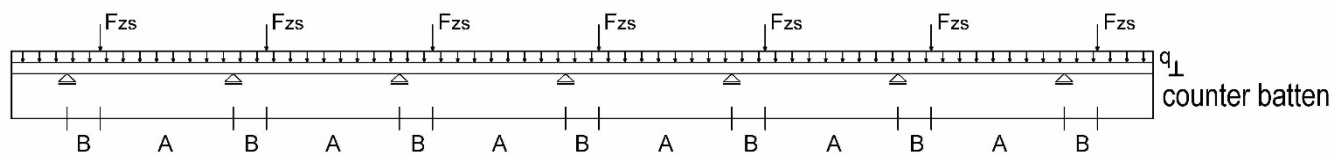

Figure A.4.5 Continuous counter batten under constant line loads from actions on the roof plane  $q_{\perp}$  and concentrated loads from tensile screws  $F_{zs}$

REISSER screws	Annex 4.8
Fastening of thermal insulation material on top of rafters	

English translation prepared by DIBt

#### A.4.3.2 Design of the screws

The design value of the load-carrying capacity of the screws may be calculated with equation (4.14) and (4.15). Screws loaded in tension:

$$F_{ax,\alpha,Rd} = \min \left\{ \frac{f_{ax,d} \cdot d \cdot l_{ef,b}}{1.2 \cdot \cos^2 \alpha_2 + \sin^2 \alpha_2} \cdot \left( \frac{\rho_{b,k}}{350} \right)^{0.8}; \frac{f_{ax,d} \cdot d \cdot l_{ef,r}}{1.2 \cdot \cos^2 \alpha_2 + \sin^2 \alpha} \cdot \left( \frac{\rho_{r,k}}{350} \right)^{0.8}; \frac{f_{tens,k}}{\gamma_{M2}} \right\} \quad (4.14)$$

Screws loaded in compression:

$$F_{ax,\alpha,Rd} = \min \left\{ \frac{f_{ax,d} \cdot d \cdot l_{ef,b}}{1.2 \cdot \cos^2 \alpha_1 + \sin^2 \alpha_1} \cdot \left( \frac{\rho_{b,k}}{350} \right)^{0.8}; \frac{f_{ax,d} \cdot d \cdot l_{ef,r}}{1.2 \cdot \cos^2 \alpha_1 + \sin^2 \alpha_1} \cdot \left( \frac{\rho_{r,k}}{350} \right)^{0.8}; \frac{\kappa_c \cdot N_{pl,k}}{\gamma_{M1}} \right\} \quad (4.15)$$

Where

$f_{ax,d}$	design value of the withdrawal parameter of the threaded part of the screw [N/mm <sup>2</sup> ],
$d$	outer thread diameter of the screw [mm],
$l_{ef,b}$	penetration length of the threaded part of the screw in the counter batten [mm],
$l_{ef,r}$	penetration length of the threaded part of the screw in the rafter [mm], $l_{ef} \geq 40$ mm,
$\rho_{b,k}$	characteristic density of the counter batten [kg/m <sup>3</sup> ], for LVL the assumed characteristic density shall not exceed 500 kg/m <sup>3</sup> ,
$\rho_{r,k}$	characteristic density of the rafter [kg/m <sup>3</sup> ], for LVL the assumed characteristic density shall not exceed 500 kg/m <sup>3</sup> ,
$\alpha$	angle $\alpha_1$ or $\alpha_2$ between screw axis and grain direction, $30^\circ \leq \alpha_1 \leq 90^\circ$ , $30^\circ \leq \alpha_2 \leq 90^\circ$ ,
$f_{tens,k}$	characteristic tensile capacity of the screw in accordance with Annex 2 [N],
$\gamma_{M1}, \gamma_{M2}$	partial factor in accordance with EN 1993-1-1,
$\kappa_c \cdot N_{pl,k}$	buckling capacity of the screw given in Table A.4.2 [N].

REISSER screws	Annex 4.9
Fastening of thermal insulation material on top of rafters	

English translation prepared by DIBt

Table A.4.2 Characteristic buckling capacity of the screws  $\kappa_c \cdot N_{pl,k}$  in N

Free screw length $l$ between counter batten and rafter [mm]	UHB screws
	Outer thread diameter $d$ [mm]
	8.0/10.0
	$\kappa_c \cdot N_{pl,k}$ [N]
≤ 100	13300
120	10400
140	8300
160	6800
180	5600
200	4700
220	4000
240	3500
260	3000
280	2700
300	2300
320	2100
340	1900
360	1700
380	1500
400	1400

REISSER screws	Annex 4.10
Fastening of thermal insulation material on top of rafters	

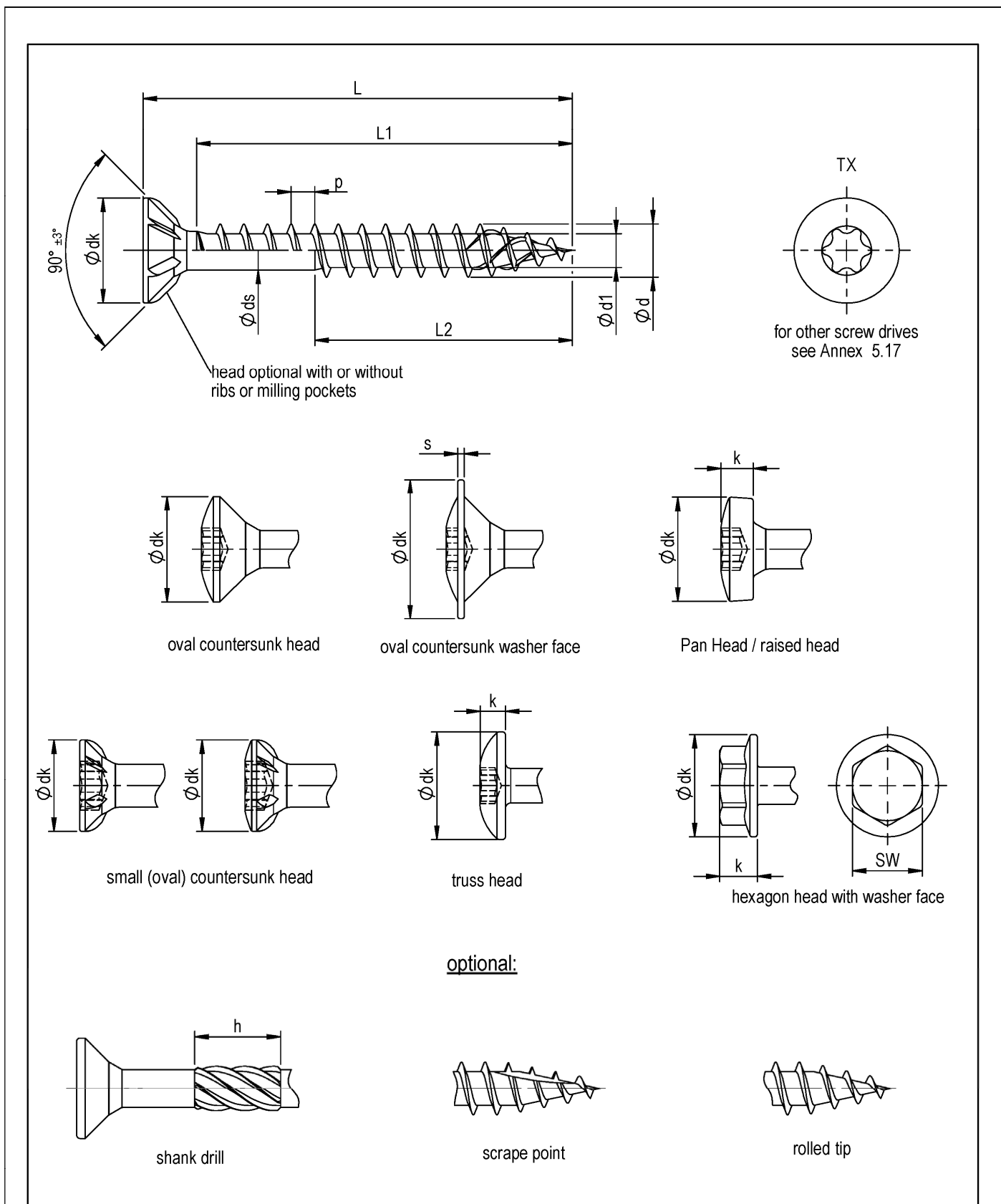

REISSER screws

R2, HBS, TKS and Vi-Port screws with single thread made of carbon steel,  
RETINOX screws with single thread made of stainless steel,  
Wooden façade screws with single thread made of stainless steel

Annex 5.1

REISSER R2, RETINOX, HBS, TKS and Vi-Port and Wooden facade screws with single thread												
thread dimensions					h							
$\varnothing d$	$\varnothing d1$	$\varnothing ds$	p	$\pm 10\%$								
3,0	1,8	2,2	1,35	5,0								
3,5	2,1	2,6	1,6	6,0								
4,0	2,4	2,8	1,8	7,0								
4,5	2,6	3,1	2,0	8,0								
5,0	3,1	3,6	2,2	8,0								
6,0	3,6	4,2	2,6	10,0								
head shapes												
$\varnothing d$	(oval) countersunk head	Truss head		small (oval) countersunk head	oval countersunk washer face		Panhead/ raised head		hexagon head with washer face			
	dk $\pm 0,5$	dk min.	k min.	dk $\pm 0,3$	dk $\pm 0,3$	s $\pm 0,2$	dkp $-0,5$	k $\pm 0,2$	SW	dkbp max.	k	
3,0	6,0	6,0	2,1		7,1	0,6	6,0	2,3				
3,5	7,0	7,0	2,1	5,0	8,1	0,6	7,0	2,6				
4,0	8,0	8,0	2,1	6,0	9,2	0,9	8,0	3,0				
4,5	9,0	9,0	2,3	7,0	10,3	0,9	9,0	3,2				
5,0	10,0	10,0	2,3	8,0	11,0	1,1	10,0	3,7	8	11,4	3,5	
6,0	12,0	12,0	2,3	11,0	13,8	1,1	12,0	4,5	10			
d	3,0	3,5	4,0	4,5	5,0	6,0						
L*	L1# $\pm 2,0$	L2# $\pm 2,0$	L1# $\pm 2,0$	L2# $\pm 2,0$	L1# $\pm 2,0$	L2# $\pm 2,0$	L1# $\pm 2,0$	L2# $\pm 2,0$	L1# $\pm 2,0$	L2# $\pm 2,0$	L1# $\pm 2,0$	L2# $\pm 2,0$
16 <sup>-0,90</sup>	12	min. 12 - max. 31										
20 <sup>-1,05</sup>	16		16		16							
25 <sup>-1,05</sup>	21		21	min. 14 - max. 31	21		21		21			
30 <sup>-1,05</sup>	26		26		26		26		26		26	
35 <sup>-1,25</sup>	31		31		31	min. 16 - max. 50	31		31		31	
40 <sup>-1,25</sup>	36		36		36		36		36		36	
45 <sup>-1,25</sup>	41		41		41		41		41		41	
50 <sup>-1,25</sup>			46		46		46		46		46	
55 <sup>-1,50</sup>							51		51		51	
60 <sup>-1,50</sup>							56		56		56	
70 <sup>-1,50</sup>								66		66		
80 <sup>-1,50</sup>										76		
90 <sup>-1,50</sup>												
100 <sup>-1,50</sup>												
110 <sup>-1,75</sup>												
120-180 <sup>-2,00</sup>												
200-300 <sup>-3,00</sup>												

\* deviant lengths between Lmin < L < Lmax possible  
# if L1, L2 ≤ 30, then tolerance ±1,5

REISSER screws

R2, HBS, TKS and Vi-Port screws with single thread made of carbon steel,  
RETINOX screws with single thread made of stainless steel,  
Wooden façade screws with single thread made of stainless steel

Annex 5.2



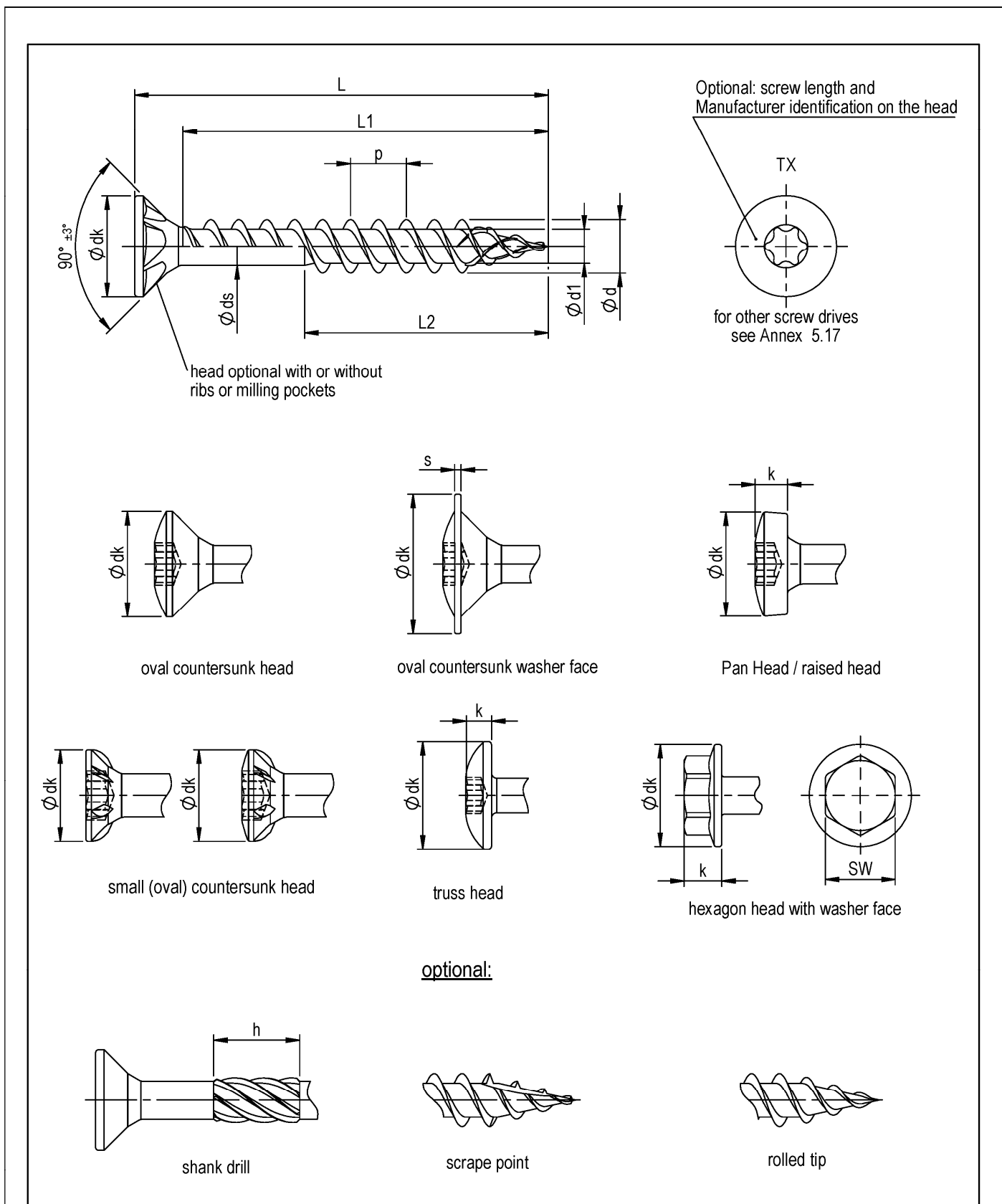

REISSER screws

DNS screws with double thread made of carbon steel,  
HBS, TKS and Vi-Port screws with double thread made of carbon steel

Annex 5.3

DNS, HBS, TKS and Vi-Port screws with double thread												
thread dimensions				h								
$\varnothing d$ <sup>+0,2</sup> / <sub>-0,3</sub>	$\varnothing d1$ <sup>+0,3</sup> / <sub>-0,1</sub>	$\varnothing ds$ $\pm 0,3$	$p$ $\pm 10\%$	h								
3,0	1,8	2,2	3,1	5,0								
3,5	2,1	2,6	3,7	6,0								
4,0	2,4	2,8	4,1	7,0								
4,5	2,6	3,1	4,5	8,0								
5,0	3,0	3,6	5,5	8,0								
6,0	3,6	4,2	6,6	10,0								
head shapes												
$\varnothing d$	(oval) countersunk head	Truss head		small (oval) countersunk head	oval countersunk washer face		Panhead/raised head		hexagon head with washer face			
	dk $\pm 0,5$	dk min.	k min.	dk $\pm 0,3$	dk <sub>s</sub> $\pm 0,3$	s $\pm 0,2$	dkp -0,5	k $\pm 0,2$	SW	dk <sub>bp</sub> max.	k	
3,0	6,0	6,0	2,1		7,1	0,6	6,0	2,3				
3,5	7,0	7,0	2,1	5,0	8,1	0,6	7,0	2,6				
4,0	8,0	8,0	2,1	6,0	9,2	0,9	8,0	3,0				
4,5	9,0	9,0	2,3	7,0	10,3	0,9	9,0	3,2				
5,0	10,0	10,0	2,3	8,0	11,0	1,1	10,0	3,7	8	11,4	3,5	
6,0	12,0	12,0	2,3	11,0	13,8	1,1	12,0	4,5	10			
d	3,0		3,5		4,0		4,5		5,0		6,0	
L*	L1# $\pm 2,0$	L2# $\pm 2,0$	L1# $\pm 2,0$	L2# $\pm 2,0$	L1# $\pm 2,0$	L2# $\pm 2,0$	L1# $\pm 2,0$	L2# $\pm 2,0$	L1# $\pm 2,0$	L2# $\pm 2,0$	L1# $\pm 2,0$	L2# $\pm 2,0$
16 <sup>-0,90</sup>	12											
20 <sup>-1,05</sup>	16		16		16							
25 <sup>-1,05</sup>	21	min. 12 - max. 31	21	min. 14 - max. 31	21	min. 16 - max. 50	21	min. 18 - max. 50	21	min. 20 - max. 70		
30 <sup>-1,05</sup>	26		26		26		26		26			
35 <sup>-1,25</sup>	31		31		31		31		31			
40 <sup>-1,25</sup>	36		36		36		36		36			
45 <sup>-1,25</sup>	41		41		41		41		41			
50 <sup>-1,25</sup>			46		46		46		46			
55 <sup>-1,50</sup>							51		51			
60 <sup>-1,50</sup>				56	56							
70 <sup>-1,50</sup>					66							
80 <sup>-1,50</sup>						76						
90 <sup>-1,50</sup>												
100 <sup>-1,50</sup>												
110 <sup>-1,75</sup>												
120-180 <sup>-2,00</sup>												
200-300 <sup>-3,00</sup>												
*deviant lengths between Lmin < L < Lmax possible # if L1, L2 ≤ 30, then tolerance ±1,5												

REISSER screws

DNS screws with double thread made of carbon steel,  
HBS, TKS and Vi-Port screws with double thread made of carbon steel

Annex 5.4

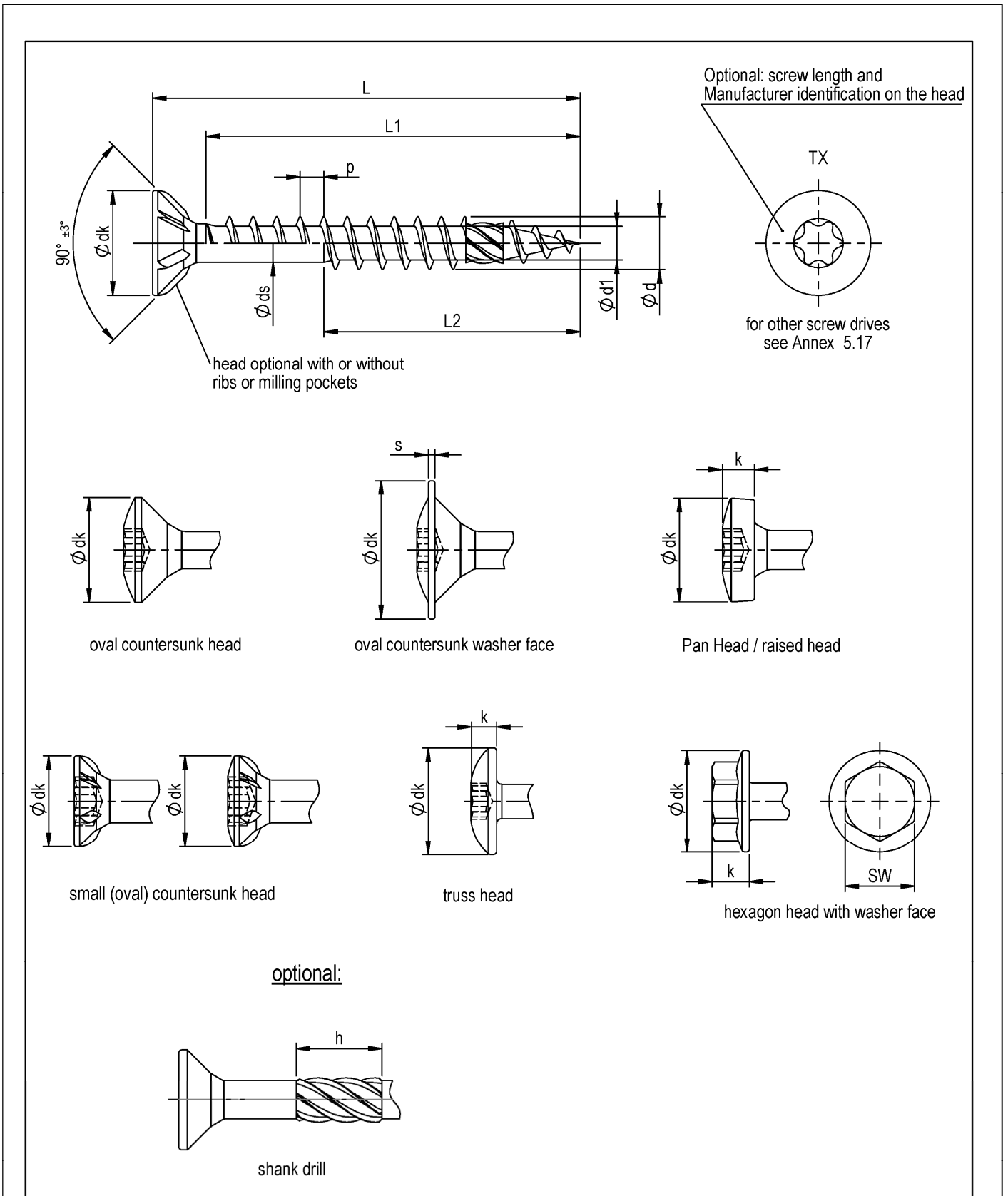

REISSER screws

DRIBO screws with single thread made of carbon steel or stainless steel,  
TKS screws with single thread made of carbon steel or stainless steel

Annex 5.5

DRIBO and TKS screws with single thread												
thread dimensions				h								
$\varnothing d$	$^{+0,2}_{-0,3}$	$\varnothing d1$	$^{+0,3}_{-0,1}$	$\varnothing ds$	$\pm 0,3$	$p$	$\pm 10\%$	h				
3,0		1,8		2,2		1,35		5,0				
3,5		2,0		2,6		1,6		6,0				
4,0		2,4		2,8		1,8		7,0				
4,5		2,6		3,2		2,0		8,0				
5,0		3,2		3,5		2,2		8,0				
6,0		3,6		4,4		2,6		10,0				
head shapes												
$\varnothing d$	(oval) countersunk head	Truss head		small (oval) countersunk head	oval countersunk washer face		Panhead/raised head		hexagon head with washer face			
	dk $\pm 0,5$	dk min.	k min.	dk $\pm 0,3$	dks $\pm 0,3$	S $\pm 0,2$	dkp $-0,5$	k $\pm 0,2$	SW	dkbp max.	k	
3,0	6,0	6,0	2,1		7,1	0,6	6,0	2,3				
3,5	7,0	7,0	2,1	5,0	8,1	0,6	7,0	2,6				
4,0	8,0	8,0	2,1	6,0	9,2	0,9	8,0	3,0				
4,5	9,0	9,0	2,3	7,0	10,3	0,9	9,0	3,2				
5,0	10,0	10,0	2,3	8,0	11,0	1,1	10,0	3,7	8	11,4	3,5	
6,0	12,0	12,0	2,3	11,0	13,8	1,1	12,0	4,5	10			
d	3,0		3,5		4,0		4,5		5,0		6,0	
L*	L1# $\pm 2,0$	L2# $\pm 2,0$	L1# $\pm 2,0$	L2# $\pm 2,0$	L1# $\pm 2,0$	L2# $\pm 2,0$	L1# $\pm 2,0$	L2# $\pm 2,0$	L1# $\pm 2,0$	L2# $\pm 2,0$	L1# $\pm 2,0$	L2# $\pm 2,0$
16 <sup>-0,90</sup>	12											
20 <sup>-1,05</sup>	16		16		16							
25 <sup>-1,05</sup>	21	min. 12 - max. 31	21	min. 14 - max. 31	21	min. 16 - max. 50	21	min. 18 - max. 50	21	min. 20 - max. 70		
30 <sup>-1,05</sup>	26		26		26		26		26			
35 <sup>-1,25</sup>	31		31		31		31		31			
40 <sup>-1,25</sup>	36		36		36		36		36			
45 <sup>-1,25</sup>	41		41		41		41		41			
50 <sup>-1,25</sup>			46		46		46		46		46	
55 <sup>-1,50</sup>			51		51		51		51		51	
60 <sup>-1,50</sup>			56		56		56		56		56	
70 <sup>-1,50</sup>			66				66		66		66	
80 <sup>-1,50</sup>									76		76	
90 <sup>-1,50</sup>												
100 <sup>-1,50</sup>												
110 <sup>-1,75</sup>												
120-180 <sup>-2,00</sup>												
200-300 <sup>-3,00</sup>												
*deviant lengths between Lmin < L < Lmax possible # if L1, L2 ≤ 30, then tolerance ±1,5												

REISSER screws

DRIBO screws with single thread made of carbon steel or stainless steel,  
TKS screws with single thread made of carbon steel or stainless steel

Annex 5.6

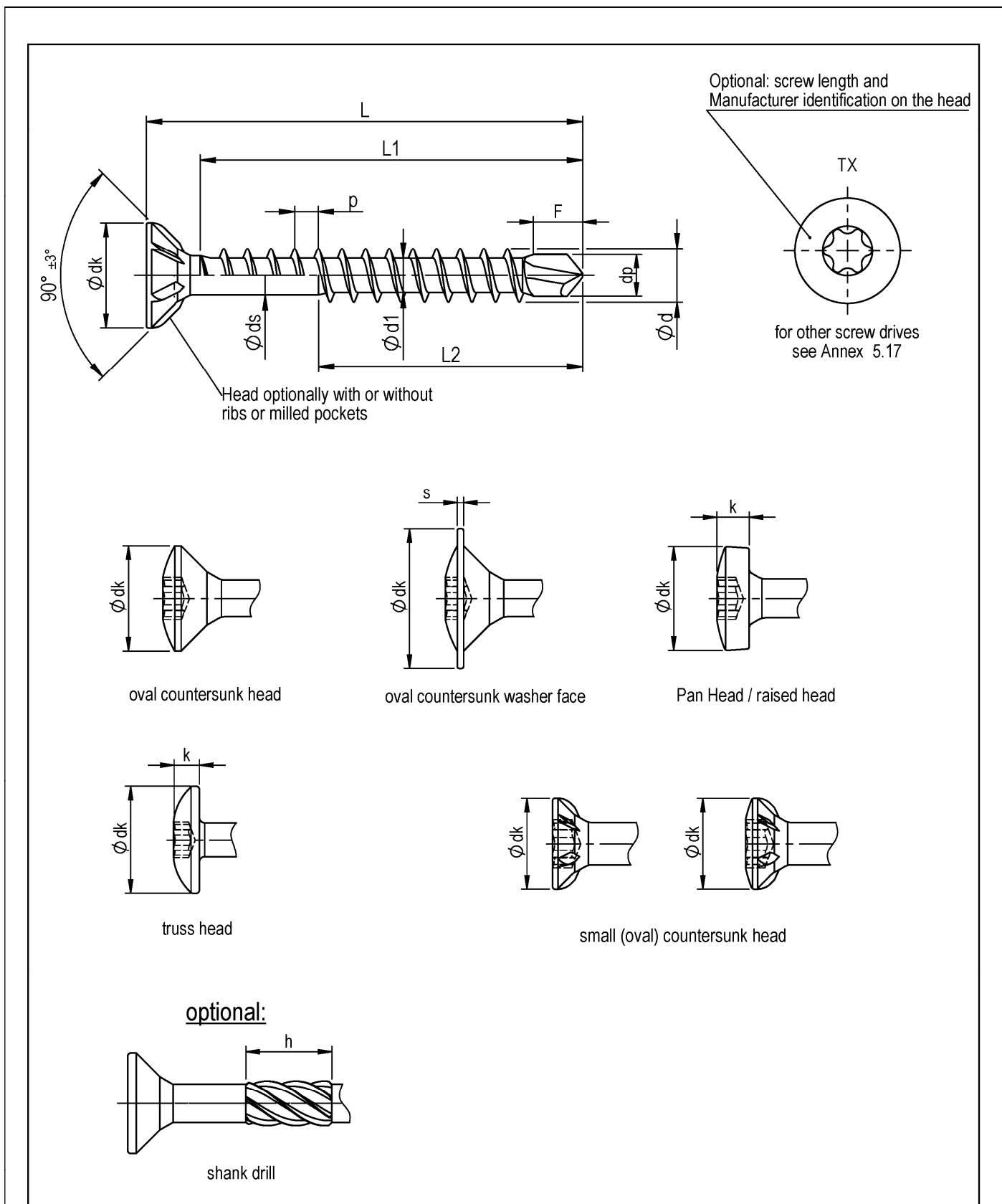

REISSER screws

SPARIBO screws with tapping point made of carbon steel or stainless steel,  
TKS screws with tapping point made of carbon steel or stainless steel

Annex 5.7

SPARIBO and tapping point screws												
thread dimensions				h	F ca.	d <sub>p</sub>						
∅ d <sup>+0,2 -0,3</sup>	∅ d1 <sup>+0,3 -0,1</sup>	∅ ds ±0,3	p ±10%									
3,5	2,0	2,6	1,6	6,0	2,8	2,2						
4,0	2,4 (2,6)	2,9	1,8	7,0	3,0	2,9						
4,5	2,6 (3,0)	3,3	2,0	8,0	3,7	3,2						
5,0 (5,3)	3,0 (3,7)	3,5 (4,0)	2,2	8,0	4,5	3,9						
6,0 (6,5)	3,6 (4,6)	4,4 (5,0)	2,6 (2,2)	10,0	4,5	4,9						
* (values in brackets only for screws made of stainless steel)												
head shapes												
∅ d	(oval) countersunk head	Truss head		small (oval) countersunk head	oval countersunk washer face		Panhead/ raised head					
	dk ±0,5	dk min.	k min.	dk ±0,3	dk <sub>s</sub> ±0,3	s ±0,2	dkp -0,5	k ±0,2				
3,5	7,0	7,0	2,1	5,0	8,1	0,6	7,0	2,6				
4,0	8,0	8,0	2,1	6,0	9,2	0,9	8,0	3,0				
4,5	9,0	9,0	2,3	7,0	10,3	0,9	9,0	3,2				
5,0	10,0	10,0	2,3	8,0	11,0	1,1	10,0	3,7				
6,0	12,0	12,0	2,3	11,0	13,8	1,1	12,0	4,5				
d	3,0		3,5		4,0		4,5		5,0		6,0	
L*	L1 <sup>#</sup> ±2,0	L2 <sup>#</sup> ±2,0	L1 <sup>#</sup> ±2,0	L2 <sup>#</sup> ±2,0	L1 <sup>#</sup> ±2,0	L2 <sup>#</sup> ±2,0	L1 <sup>#</sup> ±2,0	L2 <sup>#</sup> ±2,0	L1 <sup>#</sup> ±2,0	L2 <sup>#</sup> ±2,0	L1 <sup>#</sup> ±2,0	L2 <sup>#</sup> ±2,0
16 <sup>-0,90</sup>	12											
20 <sup>-1,05</sup>	16		16		16							
25 <sup>-1,05</sup>	21	min. 12 - max. 31	21	min. 14 - max. 42	21	min. 16 - max. 50	21	min. 18 - max. 50	21	min. 20 - max. 70		
30 <sup>-1,05</sup>	26		26		26		26		26			
35 <sup>-1,25</sup>	31		31		31		31		31			
40 <sup>-1,25</sup>	36		36		36		36		36			
45 <sup>-1,25</sup>	41		41		41		41		41			
50 <sup>-1,25</sup>			46		46		46		46		46	
55 <sup>-1,50</sup>					51		51		51		51	
60 <sup>-1,50</sup>					56		56		56		56	
70 <sup>-1,50</sup>							66		66		66	
80 <sup>-1,50</sup>									76		76	
90 <sup>-1,50</sup>												
100 <sup>-1,50</sup>												
110 <sup>-1,75</sup>												
120-180 <sup>-2,00</sup>												
200-300 <sup>-3,00</sup>												
* deviant lengths between L <sub>min</sub> < L < L <sub>max</sub> possible												
# if L1, L2 ≤ 30, then tolerance ±1,5												

REISSER screws

SPARIBO screws with tapping point made of carbon steel or stainless steel,  
TKS screws with tapping point made of carbon steel or stainless steel

Annex 5.8

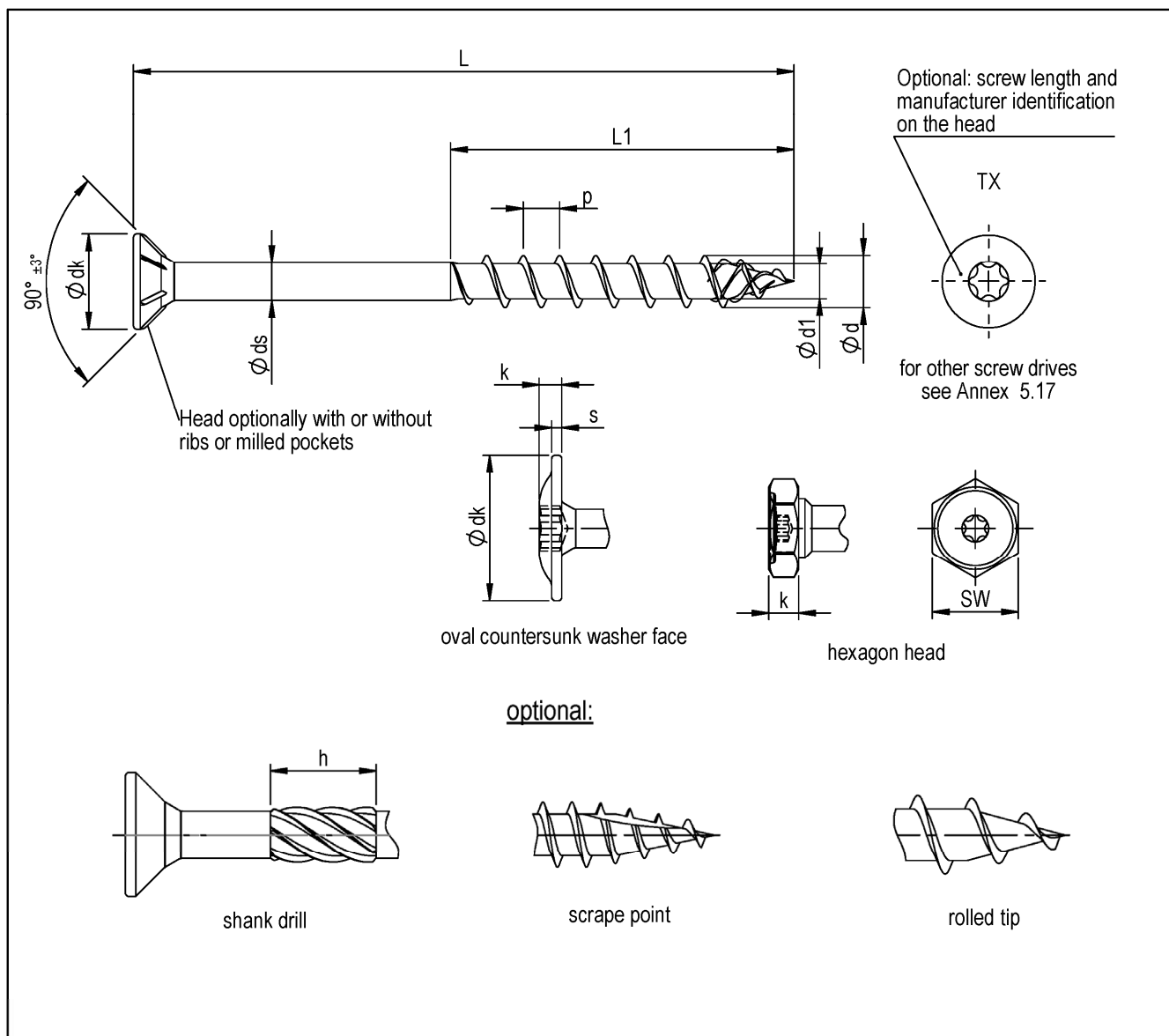

HBS, TKS and Vi-Port screws with coarse thread				head shapes						
thread dimensions					countersunk	oval countersunk washer face			hexagon head	
$\varnothing d \begin{smallmatrix} +0,2 \\ -0,3 \end{smallmatrix}$	$\varnothing d1 \pm 0,3$	$\varnothing ds \pm 0,2$	$p \pm 10\%$	$h \pm 2$	$\varnothing dk \pm 0,6$	$\varnothing dk \pm 1,0$	$k \pm 0,3$	$s \pm 0,3$	SW	$k \pm 1,0$
8,0	5,2	5,8	5,5	12,0	14,5	22	4,0	1,6	12	4,5
10,0	6,25	7,0	6,6	12,0	17,8	24	4,8	2,0	15	5,5
12,0	7,12	8,2	6,8	12,0	20,0	30	5,5	2,4	17	6,5

d	8,0	10,0	12,0
L	$L1 \pm 2,0$	$L1 \pm 2,0$	$L1 \pm 2,0$
70 - 500	min. 32 - max. 90	min. 40 - max. 90	min. 48 - max. 90

REISSER screws

HBS, TKS and Vi-Port screws with coarse thread made of carbon steel

Annex 5.9

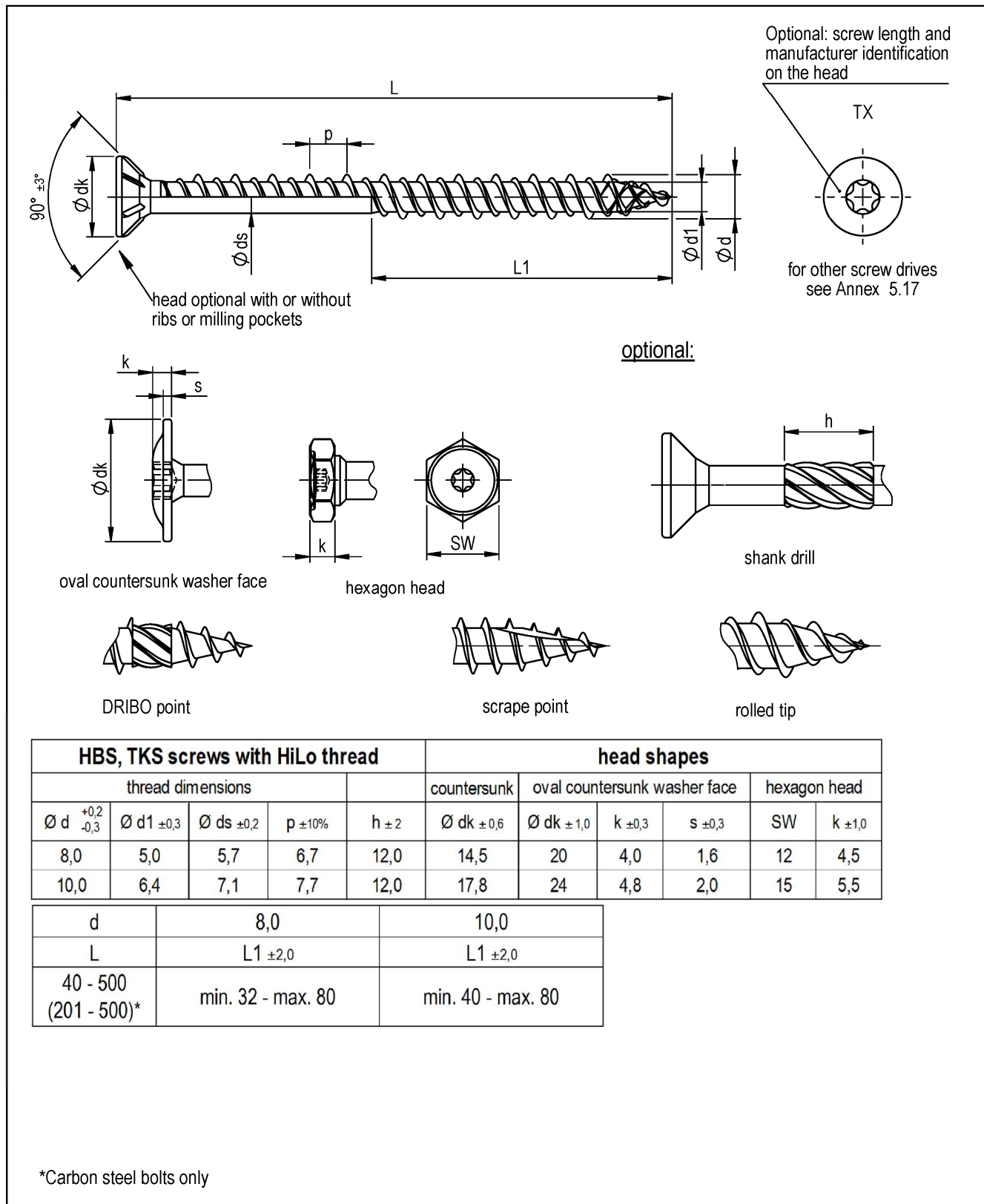

REISSER screws

HBS and TKS screws with HiLo thread made of carbon steel or stainless steel

Annex 5.10



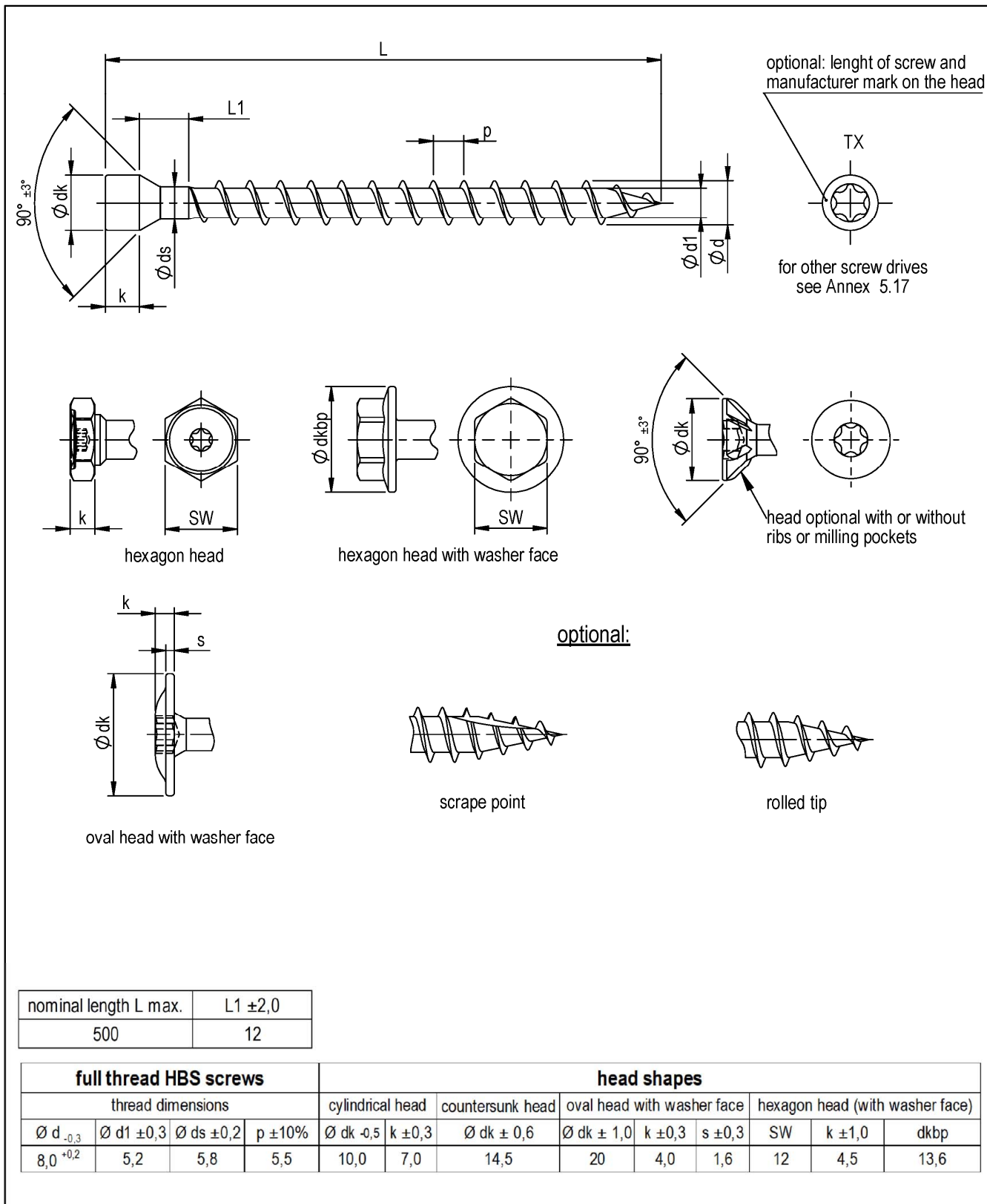

REISSER screws

Full thread HBS screws made of carbon steel

Annex 5.11

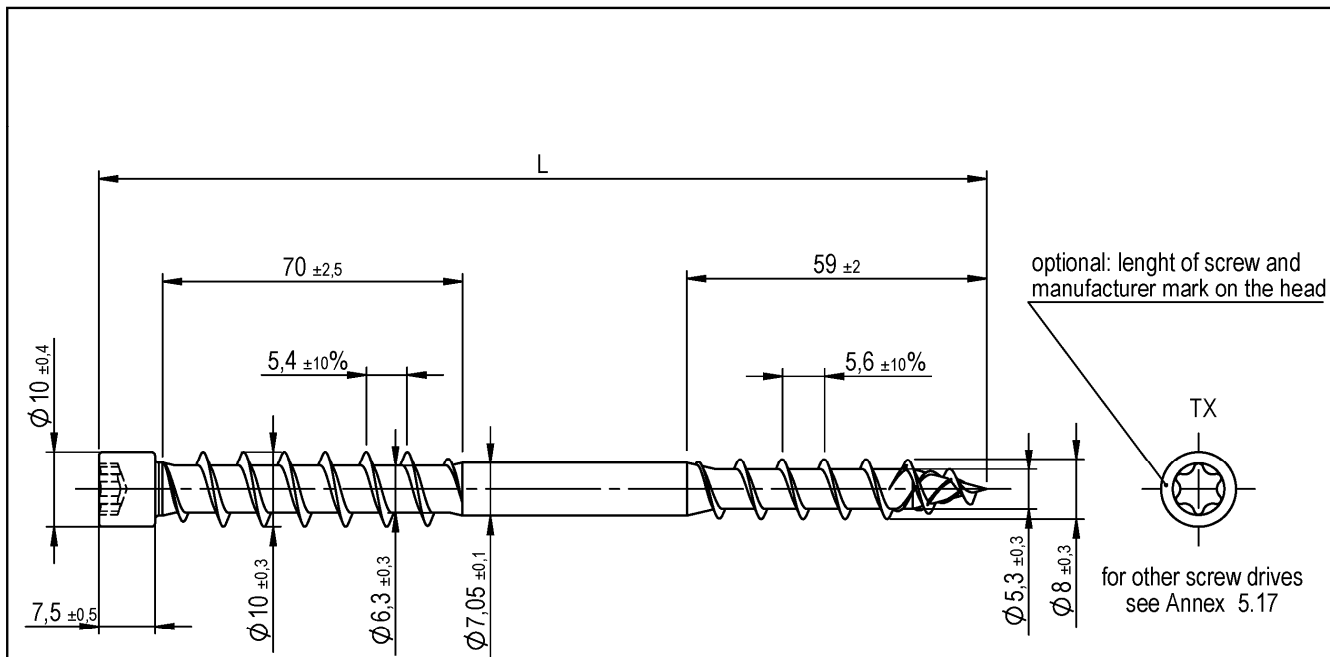

nominal diameter 8,0 mm

L	L min
160	158
180	178
200	197
220	217
230	227
240	237
250	247
260	257
270	267
280	277
300	297
320	317
330	327
340	337
350	347
360	357
380	377
400	397
420	417
440	437
460	457
480	477
500	497

optional:



friction wings



rolled tip



scrape point



tapping point

REISSER screws

UHB and Vi-Port screws with thread under head  $d = 8.0$  mm made of carbon steel

Annex 5.12

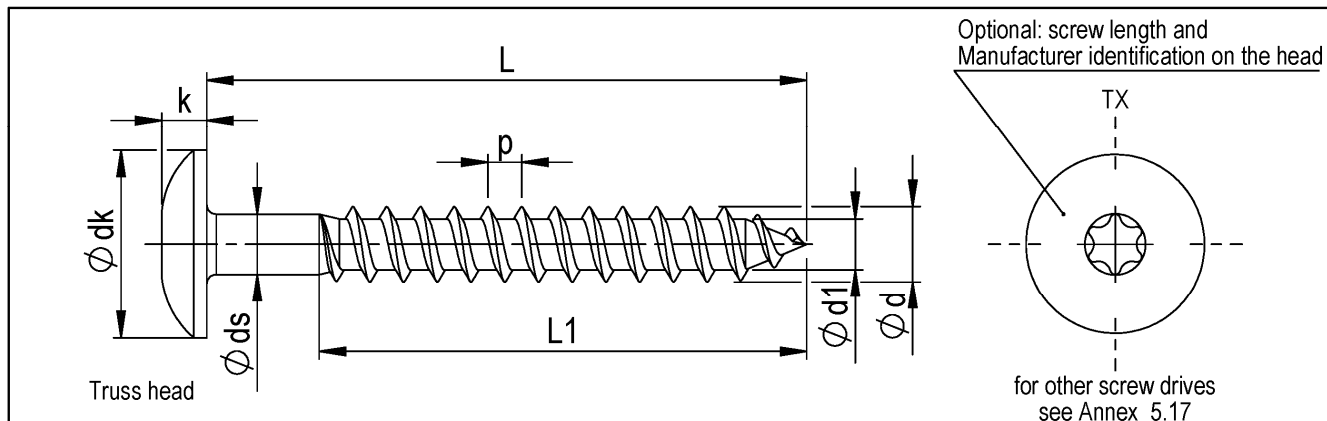

**alternativ:**



scrape point



SPI - point

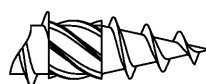

DRIBO point



tapping point

**Facade panel screws with truss head**

thread dimensions				head shape	
Ø d	Ø d1	Ø ds ±0,2	p ±10%	Ø dk	k
4,2 <sup>-0,2</sup>	2,6 <sup>+0,3</sup>	3,2	1,8	min. 9,8	min. 2,1
4,8 <sup>+0,2</sup>	3,2 <sup>+0,2</sup>	3,8	2,2	min. 11,8	min. 2,3
5,5 <sup>-0,3</sup>	3,5 <sup>+0,2</sup>	4,1	2,4	min. 11,8	min. 2,3

Ø d	4,2	4,8	5,5
L*	L1# ±2,0	L1# ±2,0	L1# ±2,0
25 <sup>-1,5</sup>	min. 17mm- max 50mm	min. 20mm- max 50mm	min. 22mm- max 50mm
32 <sup>-1,5</sup>			
33 <sup>-1,5</sup>			
35 <sup>-1,5</sup>			
38 <sup>-1,5</sup>			
40 <sup>-1,5</sup>			
45 <sup>-1,5</sup>			
50 <sup>-1,5</sup>			
55 <sup>-1,5</sup>			
60 <sup>-2,5</sup>			
64 <sup>-2,5</sup>			
80 <sup>-2,5</sup>			

\* Intermediate lengths L<sub>min</sub> < L < L<sub>max</sub> are possible  
# if L1 ≤ 30, then tolerance ±1,5

REISSER screws

Façade panels screws (FPS) with truss head made of carbon steel or stainless steel

Annex 5.13

English translation prepared by DIBt

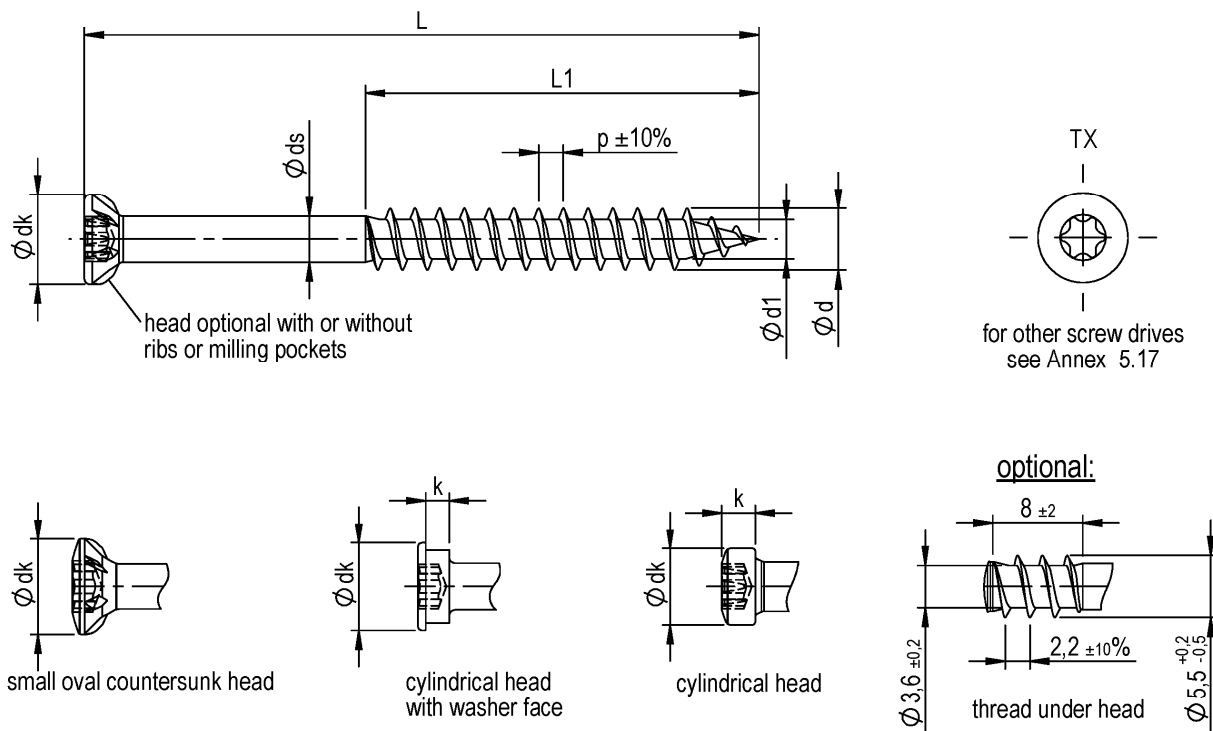

optional:

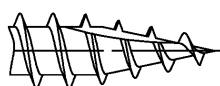

scrape point



SPi - point

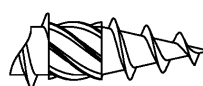

DRIBO point



tapping point

**Terrace screw ( thread acc. to annex 5.5)**

thread dimensions				small oval countersunk head / cylindrical head with washer face		cylindrical head	
$\varnothing d_{-0,5}$	$\varnothing d1 \pm 0,2$	$\varnothing ds \pm 0,2$	$p \pm 10\%$	$\varnothing dk \pm 0,3$	$k \pm 0,2$	$\varnothing dk \pm 0,3$	$k \pm 0,3$
5,5 <sup>-0,2</sup>	3,6	4	2,2	7,7	2,8	6,8	3,0

L -1,5	L1 <sup>#</sup> ±2,0
35	20
40	25
45	25
50	35 (30)
60	35 (33)
70	35 (40)
80	35
90	50

thread length in brackets only  
for screws with thread under head

# if  $L1 \leq 30$ , then tolerance  $\pm 1,5$

REISSER screws

Terrace screws made of carbon steel or stainless steel

Annex 5.14

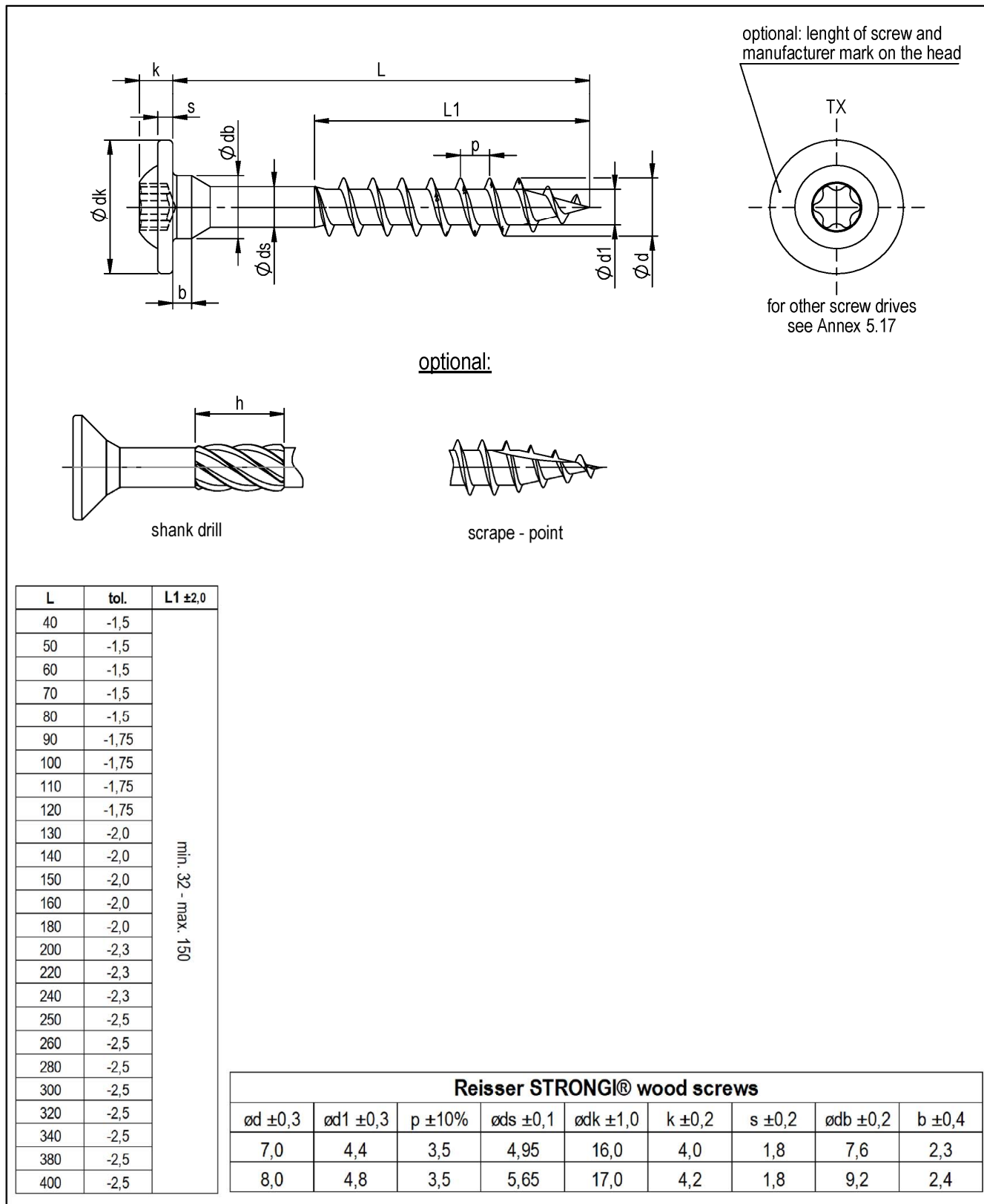

REISSER screws

STRONGI® wood screws made from carbon steel

Annex 5.15

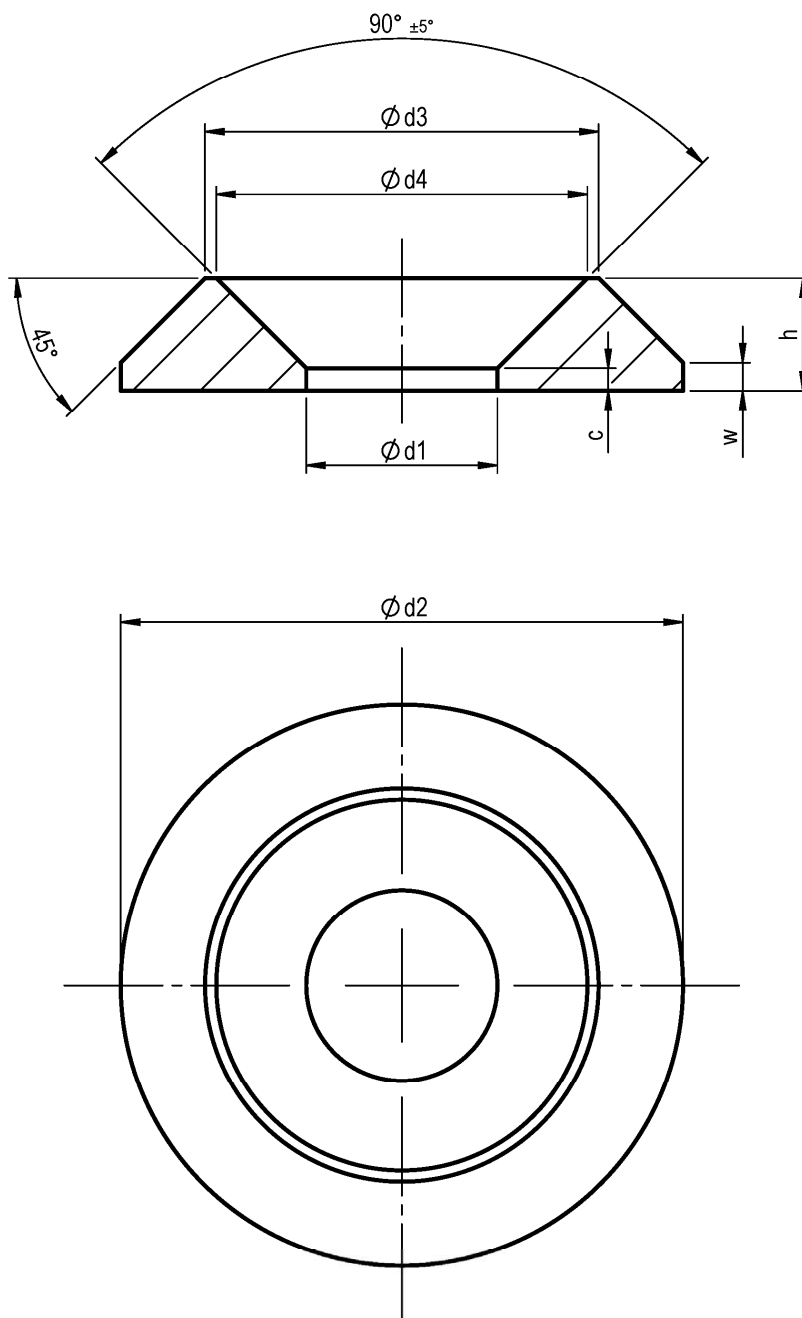

	$d1 \pm 0,3$	$d2 \pm 0,3$	$d3 \pm 0,3$	$d4 \pm 0,3$	$h \pm 0,3$	w	c
$\phi 8,0$	8,5	25,0	17,5	16,5	5,0	~ 1,25	~ 1,0
$\phi 10,0$	11,0	32,0	22,5	21,5	6,0	~ 1,4	~ 0,75

Washers made of carbon steel shall be only used with screws made of carbon steel.  
Screws made of stainless steel shall not be used with washers made of carbon steel.

REISSER screws

Countersunk washers for HBS and Vi-Port screws made of carbon steel

Annex 5.16

cross recess type H

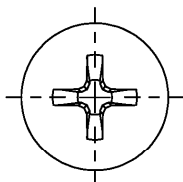

cross recess type Z

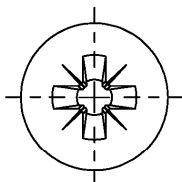

hexagon socket

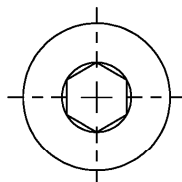

hexagon head

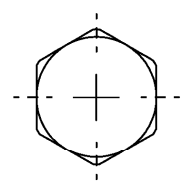

TX

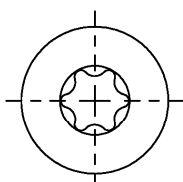

TX Pin

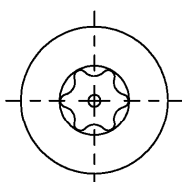

Torx® Ttap®

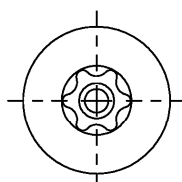

SIT®

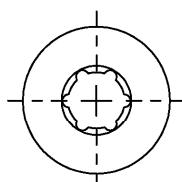

sizes of screw drives

screw drive	Ø 3,0	Ø 3,5	Ø 4,0	Ø 4,5	Ø 5,0	Ø 5,5	Ø 6,0	Ø 7,0	Ø 8,0	Ø 10	Ø 12
cross recess type H	1	1 / 2	2	2	2	2 / 3	3	3			
cross recess type Z											
TX	10	10 / 15 / 20	15 / 20	20	20 / 25	20 / 25	25 / 30	30	30 / 40	40 / 50	40 / 50
TX Pin											
Torx® Ttap®											
SIT®											
hexagon head					SW8		SW10		SW12	SW15	SW17
hexagon socket					SW 4		SW 5		SW 6		

REISSER screws

Overview screw drives

Annex 5.17

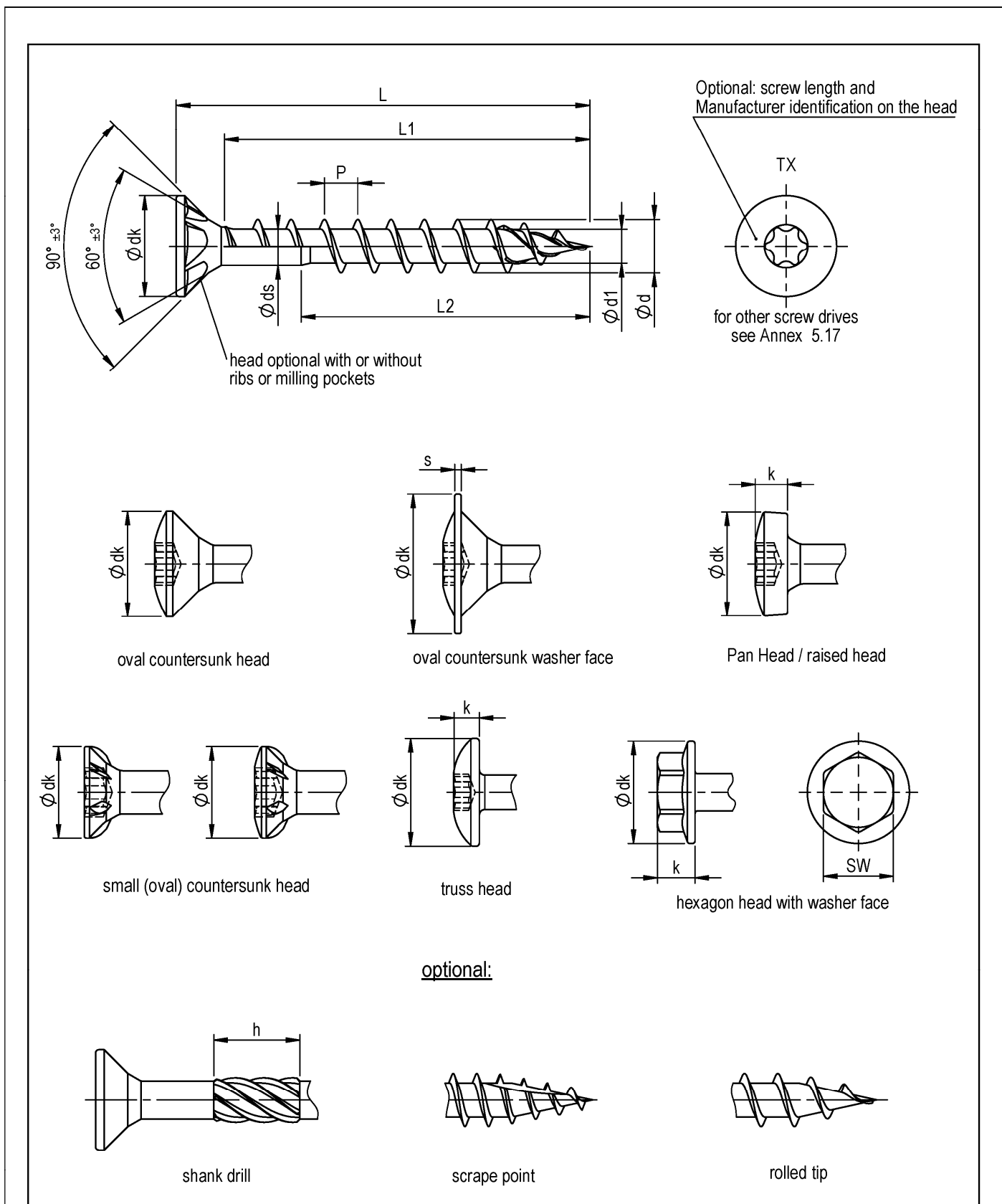

REISSER screws

DNS screws with coarse thread made of carbon steel,  
HBS, TKS with coarse thread made of carbon steel

Annex 5.18



**DNS, HBS and TKS screws with coarse thread**

thread dimensions

$\varnothing d$ <sup>+0,2</sup> / <sub>-0,3</sub>	$\varnothing d1$ <sup>+0,3</sup> / <sub>-0,1</sub>	$\varnothing ds$ $\pm 0,3$	p $\pm 10\%$	h		
5,0	3,0	3,5	3,1	8,0		
6,0	3,6	4,1	3,6	10,0		

head shapes

$\varnothing d$	(oval) countersunk head	Truss head		small (oval) countersunk head	oval countersunk washer face		Panhead/ raised head		hexagon head with washer face		
	dk $\pm 0,5$	dk min.	k min.	dk $\pm 0,3$	dks $\pm 0,3$	s $\pm 0,2$	dkp -0,5	k $\pm 0,2$	SW	dk max.	k
5,0	10,0	10,0	2,3	8,0	11,0	1,1	10,0	3,7	8	11,5	5,1
6,0	12,0	12,0	2,3	11,0	13,8	1,1	12,0	4,5	10	13,2	6,3

d	5,0		6,0	
L*	L1# $\pm 2,0$	L2# $\pm 2,0$	L1# $\pm 2,0$	L2# $\pm 2,0$
16 <sup>-0,90</sup>				
20 <sup>-1,05</sup>				
25 <sup>-1,05</sup>	21			
30 <sup>-1,05</sup>	26		26	
35 <sup>-1,25</sup>	31		31	
40 <sup>-1,25</sup>	36	min. 20 - max. 70	36	
45 <sup>-1,25</sup>	41		41	
50 <sup>-1,25</sup>	46		46	
55 <sup>-1,50</sup>	51		51	min. 24 - max. 80
60 <sup>-1,50</sup>	56		56	
70 <sup>-1,50</sup>	66		66	
80 <sup>-1,50</sup>	76		76	
90 <sup>-1,50</sup>				
100 <sup>-1,50</sup>				
110 <sup>-1,75</sup>				
120-180 <sup>-2,00</sup>				
200-300 <sup>-3,00</sup>				

\*deviant lengths between Lmin < L < Lmax possible

# if L1, L2 ≤ 30, then tolerance ±1,5

REISSER screws

DNS screws with coarse thread made of carbon steel,  
HBS, TKS with coarse thread made of carbon steel

Annex 5.19