



ETA-Danmark A/S
Göteborg Plads 1
DK-2150 Nordhavn
Tel. +45 72 24 59 00
Fax +45 72 24 59 04
Internet www.etadanmark.dk

Authorised and notified according
to Article 29 of the Regulation (EU)
No 305/2011 of the European
Parliament and of the Council of 9
March 2011

MEMBER OF EOTA



European Technical Assessment ETA-18/0850 of 2018/11/18

I General Part

Technical Assessment Body issuing the ETA and designated according to Article 29 of the Regulation (EU) No 305/2011: ETA-Danmark A/S

Trade name of the construction product:

RF Self-tapping screws for timber structures

Product family to which the above construction product belongs:

Screws for use in timber constructions

Manufacturer:

RAY FU Enterprise Co. Ltd.,
23F-1, No. 366, Boai 2nd Road
Tso Ying District
Kaohsiung 81358
Taiwan, R.O.C

Manufacturing plant:

RAY FU Enterprise Co. Ltd.,

This European Technical Assessment contains:

25 pages including 3 annexes which form an integral part of the document

This European Technical Assessment is issued in accordance with Regulation (EU) No 305/2011, on the basis of:

European Assessment document (EAD) no. EAD 130118-00-0603 "Screws for use in timber constructions"

This version replaces:

-

Translations of this European Technical Assessment in other languages shall fully correspond to the original issued document and should be identified as such.

Communication of this European Technical Assessment, including transmission by electronic means, shall be in full (excepted the confidential Annex(es) referred to above). However, partial reproduction may be made, with the written consent of the issuing Technical Assessment Body. Any partial reproduction has to be identified as such.

II SPECIFIC PART OF THE EUROPEAN TECHNICAL ASSESSMENT

1 Technical description of product and intended use

Technical description of the product

RF Self-tapping screws are screws to be used in timber structures. They shall be threaded over a part of the length or over the whole length. The screws shall be produced from carbon steel wire for nominal diameters between 3,0 mm and 12,0 mm. Where corrosion protection is required, the material or coating shall be declared in accordance with the relevant specification given in Annex A of EN 14592.

Geometry and Material

The nominal diameter (outer thread diameter), d , of RF Self-tapping screws for timber structures shall not be less than 3,0 mm and shall not be greater than 12,0 mm. The overall length of the screws, ℓ , shall not be less than 16 mm and shall not be greater than 600 mm. Other dimensions are given in Annex A.

The ratio of inner thread diameter to outer thread diameter d_i/d ranges from 0,60 to 0,71.

The screws are threaded over a minimum length L_1 of $4 \cdot d$ (i.e. $L_1 > 4 \cdot d$).

No breaking of screws shall be observed at a bend angle, α , of less than $(45/d^{0.7} + 20)$ degrees.

2 Specification of the intended use in accordance with the applicable EAD

The screws are used for connections in load bearing timber structures between members of solid timber (softwood), glued laminated timber, cross-laminated timber, and laminated veneer lumber, similar glued members, wood-based panels or steel.

Steel plates and wood-based panels except solid wood panels, laminated veneer lumber and cross laminated timber shall only be located on the side of the screw head.

The following wood-based panels may be used:

- Plywood according to EN 636 or ETA
- Particleboard according to EN 312 or ETA
- Oriented Strand Board, Type OSB/3 and OSB/4 according to EN 300 or ETA
- Fibreboard according to EN 622-2 and 622-3 or ETA (minimum density 650 kg/m³)
- Cement bonded particleboard according to ETA
- Solid wood panels according to EN 13353 and EN 13986, and cross laminated timber according to ETA

- Laminated Veneer Lumber according to EN 14374 or ETA
- Engineered wood products according to ETA if the ETA of the product includes provisions for the use of self-tapping screws, the provisions of the ETA of the engineered wood product apply

The screws shall be driven into softwood without pre-drilling or after pre-drilling with a diameter not larger than the inner thread diameter for the length of the threaded part and with a maximum of the smooth shank diameter for the length of the smooth shank.

The screws are intended to be used in timber connections for which requirements for mechanical resistance and stability and safety in use in the sense of the Basic Works Requirements 1 and 4 of Regulation 305/2011 shall be fulfilled.

The design of the connections shall be based on the characteristic load-carrying capacities of the screws. The design capacities shall be derived from the characteristic capacities in accordance with Eurocode 5 or an appropriate national code. Regarding environmental conditions, national provisions at the building site shall apply.

The screws are intended for use for connections subject to static or quasi static loading.

The zinc-coated screws are for use in timber structures subject to the dry, internal conditions defined by the service classes 1 and 2 of EN 1995-1-1 (Eurocode 5).

The scope of the screws regarding resistance to corrosion shall be defined according to national provisions that apply at the installation site considering environmental conditions.

The provisions made in this European Technical Assessment are based on an assumed intended working life of the screws of 50 years.

The indications given on the working life cannot be interpreted as a guarantee given by the producer or Assessment Body, but are to be regarded only as a means for choosing the right products in relation to the expected economically reasonable working life of the works.

3 Characteristics of product and assessment

Characteristic	Assessment of characteristic
3.1 Mechanical resistance and stability*) (BWR1)	
Tensile strength Screws made of carbon steel	Characteristic value $f_{\text{tens,k}}$: Screw d = 2,5 mm: 2,5 kN Screw d = 3,5 mm: 4,0 kN Screw d = 4,0 mm: 5,0 kN Screw d = 4,5 mm: 6,0 kN Screw d = 5,0 mm: 8,0 kN Screw d = 6,0 mm: 9,5 kN Screw d = 8,0 mm: 19 kN Screw d = 10,0 mm: 25 kN Screw d = 12,0 mm: 42 kN
Insertion moment	Ratio of the characteristic torsional strength to the mean insertion moment: $f_{\text{tor,k}} / R_{\text{tor,mean}} \geq 1,5$
Torsional strength Screws made of carbon steel	Characteristic value $f_{\text{tor,k}}$: Screw d = 3,0 mm: 1,6 Nm Screw d = 3,5 mm: 2,2 Nm Screw d = 4,0 mm: 3,3 Nm Screw d = 4,5 mm: 4,5 Nm Screw d = 5,0 mm: 6,1 Nm Screw d = 6,0 mm: 9,0 Nm Screw d = 8,0 mm: 24 Nm Screw d = 10,0 mm: 40 Nm Screw d = 12,0 mm: 68 Nm
3.2 Safety in case of fire (BWR2)	
Reaction to fire	The screws are made from steel classified as Euroclass A1 in accordance with EN 13501-1 and Commission Delegated Regulation 2016/364.
3.8 General aspects related to the performance of the product	
Identification	The screws have been assessed as having satisfactory durability and serviceability when used in timber structures using the timber species described in Eurocode 5 and subject to the conditions defined by service classes 1 and 2 See Annex A

*) See additional information in section 3.9 – 3.11.

3.9 Mechanical resistance and stability

The load-carrying capacities for RF Self-tapping screws for timber structures are applicable to the wood-based materials mentioned in paragraph 1 even though the term timber has been used in the following.

The characteristic lateral load-carrying capacities and the characteristic axial withdrawal capacities of RF Self-tapping screws for timber structures should be used for designs in accordance with Eurocode 5 or an appropriate national code.

Point side penetration length must be $\ell_{ef} \geq 4 \cdot d$, where d is the outer thread diameter of the screw. For the fixing of rafters, point side penetration must be at least 40 mm, $\ell_{ef} \geq 40$ mm.

ETAs for structural members or wood-based panels must be considered where applicable.

Lateral load-carrying capacity

The characteristic lateral load-carrying capacity of RF Self-tapping screws for timber structures shall be calculated according to EN 1995-1-1:2008 (Eurocode 5) using the outer thread diameter d as the nominal diameter of the screw. The contribution from the rope effect may be considered.

The characteristic yield moment shall be assumed as:

$d = 3,0$ mm:	$M_{y,k} = 1,6$ Nm
$d = 3,5$ mm:	$M_{y,k} = 2,3$ Nm
$d = 4,0$ mm:	$M_{y,k} = 3,3$ Nm
$d = 4,5$ mm:	$M_{y,k} = 4,5$ Nm
$d = 5,0$ mm:	$M_{y,k} = 5,9$ Nm
$d = 6,0$ mm:	$M_{y,k} = 9,5$ Nm
$d = 8,0$ mm:	$M_{y,k} = 20$ Nm
$d = 10,0$ mm:	$M_{y,k} = 36$ Nm
$d = 12,0$ mm:	$M_{y,k} = 58$ Nm

The embedding strength for screws in non-pre-drilled holes arranged at an angle between screw axis and grain direction, $30^\circ \leq \alpha \leq 90^\circ$ is:

$$f_{h,k} = \frac{0,082 \cdot \rho_k \cdot d^{-0,3}}{2,5 \cdot \cos^2 \alpha + \sin^2 \alpha} \quad [\text{MPa}]$$

and accordingly for screws in pre-drilled holes:

$$f_{h,k} = \frac{0,082 \cdot \rho_k \cdot (1 - 0,01 \cdot d)}{2,5 \cdot \cos^2 \alpha + \sin^2 \alpha} \quad [\text{MPa}]$$

Where

- ρ_k characteristic timber density [kg/m^3];
- d outer thread diameter [mm];
- α angle between screw axis and grain direction;

The embedding strength for screws arranged parallel to the plane of cross laminated timber, independent of the angle between screw axis and grain direction, $15^\circ \leq \alpha \leq 90^\circ$, shall be calculated from:

$$f_{h,k} = 20 \cdot d^{-0,5} \quad [\text{MPa}]$$

unless otherwise specified in the technical specification (ETA or hEN) for the cross laminated timber.

Where

d outer thread diameter [mm]

The embedding strength for screws in the wide face of cross laminated timber should be assumed as for solid timber based on the characteristic density of the outer layer. If relevant, the angle between force and grain direction of the outer layer should be taken into account.

The direction of the lateral force shall be perpendicular to the screw axis and parallel to the wide face of the cross laminated timber.

Axial withdrawal capacity

The characteristic axial withdrawal capacity of RF Self-tapping screws for timber structures at an angle of $30^\circ \leq \alpha \leq 90^\circ$ to the grain in solid timber, glued laminated timber and cross-laminated timber members shall be calculated according to EN 1995-1-1 from:

$$F_{ax,\alpha,Rk} = n_{ef} \cdot k_{ax} \cdot f_{ax,k} \cdot d \cdot \ell_{ef} \cdot \left(\frac{\rho_k}{350} \right)^{0,8} \quad [\text{N}]$$

Where

- $F_{ax,\alpha,Rk}$ characteristic withdrawal capacity of the screw at an angle α to the grain [N]
- n_{ef} effective number of screws according to EN 1995-1-1
- k_{ax} Factor, taking into account the angle α between screw axis and grain direction
 $k_{ax} = 1,0$ for $45^\circ \leq \alpha < 90^\circ$

$$k_{ax} = 0,3 + \frac{0,7 \cdot \alpha}{45} \quad \text{for } 15^\circ \leq \alpha < 45^\circ$$

- $f_{ax,k}$ Characteristic withdrawal parameter
 $3 \text{ mm} \leq d \leq 5 \text{ mm}$: $f_{ax,k} = 12 \text{ MPa}$
 $6 \text{ mm} \leq d \leq 8 \text{ mm}$: $f_{ax,k} = 11 \text{ MPa}$
 $d \geq 10 \text{ mm}$: $f_{ax,k} = 10 \text{ MPa}$

d outer thread diameter [mm]

ℓ_{ef} Penetration length of the threaded part according to EN 1995-1-1 [mm]

α Angle between grain and screw axis ($\alpha \geq 30^\circ$)

ρ_k Characteristic density [kg/m^3]

For screws arranged under an angle between screw axis and grain direction of less than 90° , the minimum threaded penetration length is:

$$\ell_{ef} \geq \min(4 \cdot d / \sin \alpha ; 20 \cdot d)$$

For screws penetrating more than one layer of cross laminated timber, the different layers may be considered proportionally.

The axial withdrawal capacity is limited by the head pull-through capacity and the tensile capacity of the screw.

Head pull-through capacity

The characteristic head pull-through capacity of RF Self-tapping screws for timber structures shall be calculated according to EN 1995-1-1 from:

$$F_{ax,\alpha,Rk} = n_{ef} \cdot f_{head,k} \cdot d_h^2 \cdot \left(\frac{\rho_k}{350} \right)^{0,8} \quad [N]$$

where:

$F_{ax,\alpha,Rk}$	Characteristic head pull-through capacity of the connection at an angle $\alpha \geq 30^\circ$ to the grain [N]
n_{ef}	Effective number of screws according to EN 1995-1-1:2008
$f_{head,k}$	Characteristic head pull-through parameter [MPa]
d_h	Diameter of the screw head or the washer [mm]. Outer diameter of heads or washers $d_k > 2,5 \cdot d$ shall not be taken into account.
ρ_k	Characteristic density [kg/m ³], for wood-based panels $\rho_k = 380 \text{ kg/m}^3$

Characteristic head pull-through parameter for RF Self-tapping screws for timber structures in connections with timber and in connections with wood-based panels with thicknesses above 20 mm:

$$f_{head,k} = 9,4 \text{ MPa}$$

Characteristic head pull-through parameter for screws in connections with wood-based panels with thicknesses between 12 mm and 20 mm:

$$f_{head,k} = 8,0 \text{ MPa}$$

Screws in connections with wood-based panels with a thickness below 12 mm (minimum thickness of the wood based panels of $1,2 \cdot d$ with d as outer thread diameter):

$$f_{head,k} = 8,0 \text{ MPa limited to } F_{ax,Rk} = 400 \text{ N}$$

The head diameter d_h shall be greater than $1,8 \cdot d_s$, where d_s is the smooth shank or the wire diameter. Otherwise the characteristic head pull-through capacity $F_{ax,\alpha,Rk} = 0$.

The minimum thickness of wood-based panels according to the clause 3.11 must be observed.

In steel-to-timber connections the head pull-through capacity is not governing.

Tensile capacity

The characteristic tensile strength $f_{tens,k}$ of RF Self-tapping screws for timber structures made of carbon steel is:

Screw $d = 3,5 \text{ mm}$:	4,29 kN
Screw $d = 4,0 \text{ mm}$:	5,08 kN
Screw $d = 4,5 \text{ mm}$:	6,32 kN
Screw $d = 5,0 \text{ mm}$:	9,35 kN
Screw $d = 6,0 \text{ mm}$:	10,2 kN
Screw $d = 8,0 \text{ mm}$:	19,3 kN
Screw $d = 10,0 \text{ mm}$:	26,8 kN
Screw $d = 12,0 \text{ mm}$:	42,7 kN

For screws used in combination with steel plates, the tear-off capacity of the screw head including a washer shall be greater than the tensile capacity of the screw.

Combined laterally and axially loaded screws

For connections subjected to a combination of axial and lateral load, the following expression should be satisfied:

$$\left(\frac{F_{ax,Ed}}{F_{ax,Rd}} \right)^2 + \left(\frac{F_{la,Ed}}{F_{la,Rd}} \right)^2 \leq 1$$

where

$F_{ax,Ed}$	axial design load of the screw
$F_{la,Ed}$	lateral design load of the screw
$F_{ax,Rd}$	design load-carrying capacity of an axially loaded screw
$F_{la,Rd}$	design load-carrying capacity of a laterally loaded screw

Slip modulus

The axial slip modulus K_{ser} of a screw for the serviceability limit state should be taken independent of angle α to the grain as:

$$C = K_{ser} = 780 \cdot d^{0,2} \cdot \ell_{ef}^{0,4} \quad [N/mm]$$

Where

d	outer thread diameter [mm]
ℓ_{ef}	thread penetration length in the structural member [mm]

Thermal insulation material on top of rafters

RF Self-tapping screws for timber structures with an outer thread diameter of $d = 6 \text{ mm}$, 8 mm , 10 mm and 12 mm may be used for the fixing of thermal insulation material on top of rafters.

The thickness of the insulation ranges up to 300 mm. The rafter insulation must be placed on top of solid timber or glued laminated timber rafters or cross-laminated timber members and be fixed by battens placed parallel to the rafters or by wood-based panels on top of the insulation layer. The insulation of vertical facades is also covered by the rules given here.

Screws must be screwed in the rafter through the battens or panels and the insulation without pre-drilling in one sequence. The angle α between the screw axis and the grain direction of the rafter should be between 30° and 90° .

The battens must be from solid timber (softwood) according to EN 338:2003-04. The minimum thickness of the battens is 80 mm and the minimum width 100 mm for screws with outer thread diameter $d = 12$ mm. The minimum thickness of the battens is 40 mm and the minimum width 60 mm for screws with outer thread diameter $d = 10$ mm. For screws with outer thread diameter $d = 6$ mm and 8 mm the minimum thickness of the battens is 30 mm and the minimum width 50 mm.

Alternatively, to the battens, boards with a minimum thickness of 20 mm from plywood according to EN 636, particle board according to EN 312, oriented strand board OSB/3 and OSB/4 according to EN 300 or ETA and solid wood panels according to EN 13353 may be used.

The rafter consists of solid timber (softwood) according to EN 338, glued laminated timber according to EN 14081, cross-laminated timber, laminated veneer lumber according to EN 14374 or to ETA or similar glued members according to ETA and has a minimum width of 60 mm.

The insulation must comply with an ETA.

The insulation must have a minimum compressive stress of $\sigma_{10\%} = 0,05$ N/mm² at 10 % deformation according to EN 826:1996-05.

The analysis of the fixing of the insulation and battens or boards, respectively, may be carried out using the static model in Annex 12. The battens or boards, respectively, must have sufficient strength and stiffness. The maximum pressure between the battens or boards, respectively, and the insulation shall not exceed $1,1 \cdot \sigma_{10\%}$.

The characteristic axial withdrawal capacity of the screws for rafter or facade insulation shall be calculated from:

$$F_{ax,\alpha,Rk} = \min \begin{cases} k_{ax} \cdot f_{ax,k} \cdot d \cdot \ell_{ef} \cdot k_1 \cdot k_2 \left(\frac{\rho_k}{350} \right)^{0,8} \\ f_{head,k} \cdot d_h^2 \cdot \left(\frac{\rho_k}{350} \right)^{0,8} \\ f_{tens,d} \end{cases} \quad [N]$$

where

$F_{ax,\alpha,Rk}$	Characteristic withdrawal capacity of the connection at an angle α to the grain [N]
k_{ax}	Factor, taking into account the angle α between screw axis and grain direction $k_{ax} = 1,0$ for $45^\circ \leq \alpha < 90^\circ$ $k_{ax} = 0,3 + \frac{0,7 \cdot \alpha}{45}$ for $0^\circ \leq \alpha < 45^\circ$
$f_{ax,k}$	Characteristic withdrawal parameter [N/mm ²]
d	Outer thread diameter [mm]
ℓ_{ef}	Point side penetration length of the treaded part according to EN 1995-1-1:2008 [mm]
α	Angle between grain and screw axis ($\alpha \geq 30^\circ$)
k_1	$\min \{ 1; 220/t_{HI} \}$
k_2	$\min \{ 1; \sigma_{10\%}/0,12 \}$
t_{HI}	Thickness of the thermal insulation material [mm]
$\sigma_{10\%}$	Compressive stress of the thermal insulation material under 10 % deformation [N/mm ²] $\sigma_{10\%} \geq 0,05$ N/mm ²
$f_{head,k}$	Characteristic head pull-through parameter [N/mm ²]
d_h	Outer diameter of the screw head [mm]
ρ_k	Characteristic density [kg/m ³]
$f_{tens,k}$	Characteristic tensile capacity of the screw [N]

Friction forces shall not be considered for the design of the characteristic axial withdrawal capacity of the screws.

The anchorage of wind suction forces as well as the bending stresses of the battens or the boards, respectively, shall be considered in design. Additional screws perpendicular to the grain of the rafter (angle $\alpha = 90^\circ$) may be arranged if necessary.

Screws for the anchorage of rafter insulation shall be arranged according to Annex C.

The maximum screw spacing is $e_s = 1,75$ m.

3.10 Aspects related to the performance of the product

3.10.1 Corrosion protection in service class 1 and 2.

The RF Self-tapping screws for timber structures are produced from carbon wire. Screws made from carbon steel are electrogalvanised and yellow or blue chromated. The mean thickness of the zinc coating is 5µm.

3.11 General aspects related to the intended use of the product

The screws are manufactured in accordance with the provisions of the European Technical Assessment using the automated manufacturing process and laid down in the technical documentation.

The installation shall be carried out in accordance with Eurocode 5 or an appropriate national code unless otherwise is defined in the following. Instructions from RAY FU Enterprise Co. Ltd., should be considered for installation.

The screws are used for connections in load bearing timber structures between members of solid timber (softwood), glued laminated timber (softwood), cross-laminated timber (minimum diameter $d = 6,0$ mm, softwood), laminated veneer lumber (softwood), similar glued members (softwood), wood-based panels or steel members.

The screws may be used for connections in load bearing timber structures with structural members according to an associated ETA, if according to the ETA of the structural member a connection in load bearing timber structures with screws according to an ETA is allowed.

Furthermore, the screws with diameters between 6 mm and 12 mm may also be used for the fixing of insulation on top of rafters or at vertical facades.

A minimum of two screws should be used for connections in load bearing timber structures.

The minimum penetration depth in structural members made of solid, glued or cross-laminated timber is $4 \cdot d$.

Wood-based panels and steel plates should only be arranged on the side of the screw head. The minimum thickness of wood-based panels should be $1,2 \cdot d$. Furthermore, the minimum thickness for following wood-based panels should be:

- Plywood, Fibreboards: 6 mm
- Particleboards, OSB, Cement Particleboards: 8 mm
- Solid wood panels: 12 mm

For structural members according to ETA's the terms of the ETA's must be considered.

If screws with an outer thread diameter $d \geq 8$ mm are used in load bearing timber structures, the structural solid or glued laminated timber, laminated veneer lumber and similar glued members must be from spruce, pine or fir. This does not apply for screws in pre-drilled holes.

The minimum angle between the screw axis and the grain direction is $\alpha = 30^\circ$.

The screws shall be driven into the wood without pre-drilling or after pre-drilling with a diameter equal or less than the inner thread diameter.

The hole diameter in steel members must be predrilled with a suitable diameter.

Only the equipment prescribed by RAY FU Enterprise Co. Ltd., shall be used for driving the screws.

In connections with screws with countersunk head according to Annex A the head must be flush with the surface of the connected structural member. A deeper countersink is not allowed.

For structural timber members, minimum spacing and distances for screws are given in EN 1995-1-1 (Eurocode 5) clause 8.3.1.2 and table 8.2 as for nails in predrilled or non-predrilled holes, respectively. Here, the outer thread diameter d must be considered.

For Douglas fir members minimum spacing and distances parallel to the grain shall be increased by 50%.

Minimum distances from the unloaded edge perpendicular to the grain may be reduced to $3 \cdot d$, if the spacing parallel to the grain and the end distance is at least $25 \cdot d$.

Unless specified otherwise in the technical specification (ETA or hEN) of cross laminated timber, minimum distances and spacing for screws in the wide face of cross laminated timber members with a minimum thickness $t = 10 \cdot d$ may be taken as (see Annex B):

Spacing a_1 parallel to the grain	$a_1 = 4 \cdot d$
Spacing a_2 perpendicular to the grain	$a_2 = 2,5 \cdot d$
Distance $a_{3,c}$ from centre of the screw-part in timber to the unloaded end grain	$a_{3,c} = 6 \cdot d$
Distance $a_{3,t}$ from centre of the screw-part in timber to the loaded end grain	$a_{3,t} = 6 \cdot d$
Distance $a_{4,c}$ from centre of the screw-part in timber to the unloaded edge	$a_{4,c} = 2,5 \cdot d$
Distance $a_{4,t}$ from centre of the screw-part in timber to the loaded edge	$a_{4,t} = 6 \cdot d$

Unless specified otherwise in the technical specification (ETA or hEN) of cross laminated timber, minimum distances and spacing for screws in the edge surface of cross laminated timber members with a minimum thickness $t = 10 \cdot d$ and a minimum penetration depth perpendicular to the edge surface of $10 \cdot d$ may be taken as (see Annex B):

Spacing a_1 parallel to the CLT plane	$a_1 = 10 \cdot d$
Spacing a_2 perpendicular to the CLT plane	$a_2 = 4 \cdot d$
Distance $a_{3,c}$ from centre of the screw-part in timber to the unloaded end	$a_{3,c} = 7 \cdot d$
Distance $a_{3,t}$ from centre of the screw-part in timber to the loaded end	$a_{3,t} = 12 \cdot d$
Distance $a_{4,c}$ from centre of the screw-part in timber to the unloaded edge	$a_{4,c} = 3 \cdot d$
Distance $a_{4,t}$ from centre of the screw-part in timber to the loaded edge	$a_{4,t} = 6 \cdot d$

For a crossed screw couple, the minimum spacing between the crossing screws is $1,5 \cdot d$.

Minimum thickness for structural members is $t = 24$ mm for screws with outer thread diameter $d < 8$ mm, $t = 30$ mm for screws with outer thread diameter $d = 8$ mm, $t = 40$ mm for screws with outer thread diameter $d = 10$ mm and $t = 80$ mm for screws with outer thread diameter $d = 12$ mm.

4 Attestation and verification of constancy of performance (AVCP)

4.1 AVCP system

According to the decision 97/176/EC of the European Commission¹, as amended, the system(s) of assessment and verification of constancy of performance (see Annex V to Regulation (EU) No 305/2011) is 3.

5 Technical details necessary for the implementation of the AVCP system, as foreseen in the applicable EAD

Technical details necessary for the implementation of the AVCP system are laid down in the control plan deposited at ETA-Danmark prior to CE marking.

Issued in Copenhagen on 2018-11-18 by



Thomas Bruun
Managing Director, ETA-Danmark

Annex A
Drawings and material specification of RF Self-tapping screws for timber structures

RF Self-tapping screw fine thread															
Self-drilling with full or part thread, Carbon Steel, Countersunk Head															
Tip: sharp, Type 17, Saw Thread and Type 17 & Saw Thread combined Shank Rips: optional for $L \geq 25\text{mm}$ and $d \geq 3,5$; obligatory for $L > 200\text{mm}$ Thread Cutting Line: optional Head Mark: optional Under Head Rips or Pockets: optional															
Nominal diameter (d)			3		3,5		4		4,5		5		6		
d	Major Diameter	min	2,75		3,30		3,75		4,25		4,75		5,80		
		max	3,00		3,50		4,00		4,50		5,00		6,00		
d1	Minor Diameter	min	1,70		2,00		2,25		2,45		2,70		3,40		
		max	2,10		2,20		2,50		2,70		3,00		3,70		
dh	Head Diameter	min	5,60		6,60		7,50		8,50		9,50		11,50		
		max	6,00		7,00		8,00		9,00		10,00		12,00		
ds	Shaft Diameter	min	2,15		2,45		2,72		3,10		3,40		4,20		
h	Head Height	min	2,60		3,20		4,00		4,30		4,80		5,10		
		max	3,00		3,60		4,40		4,70		5,20		5,50		
p	Pitch	min	1,22		1,44		1,62		1,80		1,98		2,34		
		max	1,49		1,76		1,98		2,20		2,42		2,86		
L	Length	min	16	+1,0 -2,0	18	+1,0 -2,0	20	+1,0 -2,0	25	+1,0 -2,0	25	+1,0 -2,0	30	+1,0 -2,0	
		max	50	+1,0 -2,0	50	+1,0 -2,0	70	+1,0 -2,0	80	+1,0 -2,0	120	+1,0 -2,0	300	+1,0 -2,0	
L1	Thread Length	min	12	+1,0 -2,0	14	+1,0 -2,0	16	+1,0 -2,0	18	+1,0 -2,0	20	+1,0 -2,0	24	+1,0 -2,0	
		max	46	+1,0 -2,0	44	+1,0 -2,0	64	+1,0 -2,0	74	+1,0 -2,0	75	+1,0 -2,0	75	+1,0 -2,0	
L2	Shank Rips Length	min			5,00		5,00		5,00		5,00		11,00		
		max			7,00		7,00		7,00		7,00		13,00		
d2	Shank Rips Diameter	min			2,80		3,30		3,30		3,70		4,80		
		max			3,30		3,90		3,90		4,00		5,60		
Recess TX	Recess Size			10		10/15/20		15/20		20/25		20/25		25/30	
Recess PZ	Recess Size			1		2		2		2		2		3	

All dimensions and tolerances in mm.

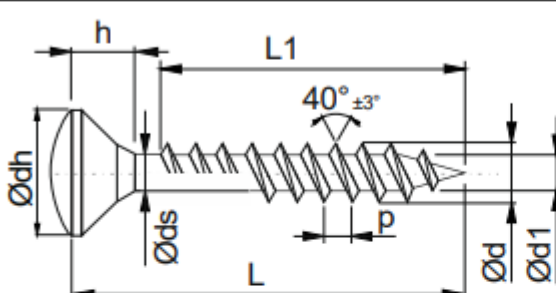
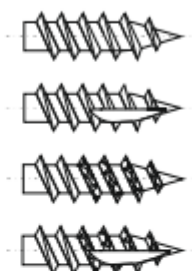
RF Self-tapping screw fine thread														
Self-drilling with full or part thread, Carbon Steel, Raised Countersunk Head														
														
		<p>Tip: sharp, Type 17, Saw Thread and Type 17 & Saw Thread combined Shank Rips: optional for $L \geq 25\text{mm}$ and $d \geq 3,5$; obligatory for $L > 200\text{mm}$ Thread Cutting Line: optional Head Mark: optional Under Head Rips or Pockets: optional</p>												
Nominal diameter (d)			3	3,5	4	4,5	5	6						
d	Major Diameter	min	2,75	3,30	3,75	4,25	4,75	5,80						
		max	3,00	3,50	4,00	4,50	5,00	6,00						
d1	Minor Diameter	min	1,70	2,00	2,25	2,45	2,70	3,40						
		max	2,10	2,20	2,50	2,70	3,00	3,70						
dh	Head Diameter	min	5,60	6,60	7,50	8,50	9,50	11,50						
		max	6,00	7,00	8,00	9,00	10,00	12,00						
ds	Shaft Diameter	min	2,15	2,45	2,72	3,10	3,40	4,20						
h	Head Height	min	2,90	3,50	4,50	4,50	5,10	5,80						
		max	3,50	4,10	5,10	5,10	5,70	6,40						
p	Pitch	min	1,22	1,44	1,62	1,80	1,98	2,34						
		max	1,49	1,76	1,98	2,20	2,42	2,86						
L	Length	min	16	$+1,0$ $-2,0$	18	$+1,0$ $-2,0$	20	$+1,0$ $-2,0$	25	$+1,0$ $-2,0$	25	$+1,0$ $-2,0$	30	$+1,0$ $-2,0$
		max	50	$+1,0$ $-2,0$	50	$+1,0$ $-2,0$	70	$+1,0$ $-2,0$	80	$+1,0$ $-2,0$	120	$+1,0$ $-2,0$	300	$+1,0$ $-2,0$
L1	Thread Length	min	12	$+1,0$ $-2,0$	14	$+1,0$ $-2,0$	16	$+1,0$ $-2,0$	18	$+1,0$ $-2,0$	20	$+1,0$ $-2,0$	24	$+1,0$ $-2,0$
		max	46	$+1,0$ $-2,0$	44	$+1,0$ $-2,0$	64	$+1,0$ $-2,0$	74	$+1,0$ $-2,0$	75	$+1,0$ $-2,0$	75	$+1,0$ $-2,0$
L2	Shank Rips Length	min		5,00	5,00	5,00	5,00	11,00						
		max		7,00	7,00	7,00	7,00	13,00						
d2	Shank Rips Diameter	min		2,80	3,30	3,30	3,70	4,80						
		max		3,30	3,90	3,90	4,00	5,60						
Recess TX	Recess Size		10	10/15/20	15/20	20/25	20/25	25/30						
Recess PZ	Recess Size		1	2	2	2	2	3						

All dimensions and tolerances in mm.

RF Self-tapping screw fine thread															
Self-drilling with full or part thread, Carbon Steel, Pan Head															
		<p>Tip: sharp, Type 17, Saw Thread and Type 17 & Saw Thread combined Shank Rips: optional for $L \geq 25\text{mm}$ and $d \geq 3,5$; obligatory for $L > 200\text{mm}$ Thread Cutting Line: optional Head Mark: optional</p>													
		Nominal diameter (d)		3		3,5		4		4,5		5		6	
d	Major Diameter	min	2,75		3,30		3,75		4,25		4,75		5,80		
		max	3,00		3,50		4,00		4,50		5,00		6,00		
d1	Minor Diameter	min	1,70		2,00		2,25		2,45		2,70		3,40		
		max	2,10		2,20		2,50		2,70		3,00		3,70		
dh	Head Diameter	min	5,60		6,60		7,50		8,50		9,50		11,50		
		max	6,00		7,00		8,00		9,00		10,00		12,00		
ds	Shaft Diameter	min	2,15		2,45		2,72		3,10		3,40		4,20		
		max													
h	Head Height	min	2,10		2,30		2,60		2,90		3,30		4,00		
		max	2,40		2,60		2,90		3,20		3,60		4,20		
p	Pitch	min	1,22		1,44		1,62		1,80		1,98		2,34		
		max	1,49		1,76		1,98		2,20		2,42		2,86		
L	Length	min	16	+1,0 -2,0	18	+1,0 -2,0	20	+1,0 -2,0	25	+1,0 -2,0	25	+1,0 -2,0	30	+1,0 -2,0	
		max	50	+1,0 -2,0	50	+1,0 -2,0	70	+1,0 -2,0	80	+1,0 -2,0	120	+1,0 -2,0	300	+1,0 -2,0	
L1	Thread Length	min	12	+1,0 -2,0	14	+1,0 -2,0	16	+1,0 -2,0	18	+1,0 -2,0	20	+1,0 -2,0	24	+1,0 -2,0	
		max	46	+1,0 -2,0	44	+1,0 -2,0	64	+1,0 -2,0	74	+1,0 -2,0	75	+1,0 -2,0	75	+1,0 -2,0	
L2	Shank Rips Length	min			5,00		5,00		5,00		5,00		11,00		
		max			7,00		7,00		7,00		7,00		13,00		
d2	Shank Rips Diameter	min			2,80		3,30		3,30		3,70		4,80		
		max			3,30		3,90		3,90		4,00		5,60		
Recess TX	Recess Size			10		10/15/20		15/20		20/25		20/25		25/30	
Recess PZ	Recess Size			1		2		2		2		2		3	

All dimensions and tolerances in mm.

RF Self-tapping screw coarse thread										
Self-drilling with full or part thread, Carbon Steel, Countersunk Head										
<p>Tip: sharp, Type 17, Saw Thread and Type 17 & Saw Thread combined Shank Rips: optional for $L \geq 25\text{mm}$ Thread Cutting Line: optional Head Mark: optional Under Head Rips or Pockets: optional</p>										
Nominal diameter (d)			3,5	4	4,5	5				
d	Major Diameter	min	3,20	3,70	4,20	4,70				
		max	3,50	4,00	4,50	5,00				
d1	Minor Diameter	min	1,90	2,05	2,40	2,80				
		max	2,10	2,50	2,90	3,30				
dh	Head Diameter	min	6,60	7,60	8,60	9,60				
		max	7,00	8,00	9,00	10,00				
ds	Shaft Diameter	min	2,50	2,80	3,16	3,47				
h	Head Height	min	3,20	4,00	4,30	4,90				
		max	3,60	4,40	4,70	5,30				
p	Pitch	min	2,43	2,52	2,79	2,88				
		max	2,97	3,08	3,41	3,52				
L	Length	min	20	+1,0 -2,0	20	+1,0 -2,0	20	+1,0 -2,0	25	+1,0 -2,0
		max	70	+1,0 -2,0	80	+1,0 -2,0	80	+1,0 -2,0	120	+1,0 -2,0
L1	Thread Length	min	14	+1,0 -3,0	16	+1,0 -3,0	18	+1,0 -3,0	20	+1,0 -3,0
		max	42	+1,0 -3,0	49	+1,0 -3,0	49	+1,0 -3,0	74	+1,0 -3,0
L2	Shank Rips Length	min	5,00	5,00	5,00	5,00				
		max	7,00	7,00	7,00	7,00				
d2	Shank Rips Diameter	min	2,80	3,30	3,30	3,70				
		max	3,30	3,90	3,90	4,00				
Recess TX	Recess Size		10/15/20	15/20	20/25	20/25				

All dimensions and tolerances in mm.

RF Self-tapping screw coarse thread										
Self-drilling with full or part thread, Carbon Steel, Countersunk Head										
<p>Tip: sharp, Type 17, Saw Thread and Type 17 & Saw Thread combined Shank Rips: obligatory Thread Cutting Line: optional Head Mark: optional Under Head Rips or Pockets: optional</p>										
Nominal diameter (d)			6		8		10		12	
d	Major Diameter	min	5,80		7,60		9,60		11,60	
		max	6,20		8,25		10,25		12,30	
d1	Minor Diameter	min	3,65		5,05		6,20		7,00	
		max	4,00		5,50		6,70		7,50	
dh	Head Diameter	min	11,40		14,00		17,00		20,00	
		max	12,20		15,00		19,00		21,50	
ds	Shaft Diameter	min	4,15		5,70		6,80		7,90	
h	Head Height	min	5,30		6,75		8,40		9,20	
		max	5,90		7,25		9,00		10,20	
p	Pitch	min	4,05		4,68		5,04		5,40	
		max	4,95		5,72		6,16		6,60	
L	Length	min	40	+2,0 -2,0	40	+2,0 -2,0	80	+2,0 -2,0	80	+2,0 -2,0
		max	300	+2,0 -2,0	600	+2,0 -2,0	600	+2,0 -2,0	600	+2,0 -2,0
L1	Thread Length	min	24	+1,5 -1,5	32	+1,5 -1,5	40	+1,5 -1,5	50	+1,5 -1,5
		max	75	+1,5 -1,5	150	+1,5 -1,5	150	+1,5 -1,5	150	+1,5 -1,5
L2	Shank Rips Length	min	11,00		11,00		11,00		11,00	
		max	13,00		13,00		13,00		13,00	
d2	Shank Rips Diameter	min	4,80		6,00		7,90		9,00	
		max	5,60		6,80		8,70		9,80	
Recess TX	Recess Size		25 / 30		40		40		40/50	

All dimensions and tolerances in mm.

RF Self-tapping screw coarse thread										
Self-drilling with full or part thread, Carbon Steel, Wafer Head										
		<p>Tip: sharp, Type 17, Saw Thread and Type 17 & Saw Thread combined Shank Rips: obligatory Thread Cutting Line: optional Head Mark: optional</p>								
Nominal diameter (d)			6		8		10		12	
d	Major Diameter	min	5,80		7,60		9,60		11,60	
		max	6,20		8,25		10,25		12,30	
d1	Minor Diameter	min	3,65		5,05		6,20		7,00	
		max	4,00		5,50		6,70		7,50	
dh	Head Diameter	min	14,50		20,50		23,50		27,50	
		max	16,10		23,50		26,50		30,50	
ds	Shaft Diameter	min	4,15		5,70		6,80		7,90	
h	Head Height	min	2,70		3,00		3,50		3,60	
		max	3,50		3,80		4,50		4,80	
p	Pitch	min	4,05		4,68		5,04		5,40	
		max	4,95		5,72		6,16		6,60	
L	Length	min	40	+2,0 -2,0	40	+2,0 -2,0	80	+2,0 -2,0	80	+2,0 -2,0
		max	300	+2,0 -2,0	600	+2,0 -2,0	600	+2,0 -2,0	600	+2,0 -2,0
L1	Thread Length	min	24	+1,5 -1,5	32	+1,5 -1,5	40	+1,5 -1,5	50	+1,5 -1,5
		max	75	+1,5 -1,5	150	+1,5 -1,5	150	+1,5 -1,5	150	+1,5 -1,5
L2	Shank Rips Length	min	11,00		11,00		11,00		11,00	
		max	13,00		13,00		13,00		13,00	
d2	Shank Rips Diameter	min	4,80		6,00		7,90		9,00	
		max	5,60		6,80		8,70		9,80	
Recess TX	Recess Size		25 / 30		40		40		40/50	

All dimensions and tolerances in mm.

RF Self-tapping screw coarse thread										
Self-drilling with full or part thread, Carbon Steel, Hex Head										
Tip: sharp, Type 17, Saw Thread and Type 17 & Saw Thread combined Shank Rips: obligatory Thread Cutting Line: optional Head Mark: optional										
Nominal diameter (d)			6		8		10		12	
d	Major Diameter	min	5,80		7,60		9,60		11,60	
		max	6,20		8,25		10,25		12,30	
d1	Minor Diameter	min	3,65		5,05		6,20		7,00	
		max	4,00		5,50		6,70		7,50	
AF	Width across flat	min	AF10 -0,4		AF12 -0,4		AF15 -0,4		AF17 -0,5	
		max	AF10		AF12		AF15		AF17	
ds	Shaft Diameter	min	4,15		5,70		6,80		7,90	
h	Head Height	min	3,70		4,20		4,60		5,10	
		max	4,50		5,00		5,80		6,30	
p	Pitch	min	4,05		4,68		5,04		5,40	
		max	4,95		5,72		6,16		6,60	
L	Length	min	40	+2,0 -2,0	40	+2,0 -2,0	80	+2,0 -2,0	80	+2,0 -2,0
		max	300	+2,0 -2,0	600	+2,0 -2,0	600	+2,0 -2,0	600	+2,0 -2,0
L1	Thread Length	min	24	+1,5 -1,5	32	+1,5 -1,5	40	+1,5 -1,5	50	+1,5 -1,5
		max	75	+1,5 -1,5	150	+1,5 -1,5	150	+1,5 -1,5	150	+1,5 -1,5
L2	Shank Rips Length	min	11,00		11,00		11,00		11,00	
		max	13,00		13,00		13,00		13,00	
d2	Shank Rips Diameter	min	4,80		6,00		7,90		9,00	
		max	5,60		6,80		8,70		9,80	
Recess TX	Recess Size		25 / 30		40		40		40/50	

All dimensions and tolerances in mm.

RF Self-tapping screw coarse thread										
Self-drilling with full or part thread, Carbon Steel, Hex-Wafer Head										
Tip: sharp, Type 17, Saw Thread and Type 17 & Saw Thread combined Shank Rips: obligatory Thread Cutting Line: optional Head Mark: optional										
Nominal diameter (d)			6		8		10		12	
d	Major Diameter	min	5,80		7,60		9,60		11,60	
		max	6,20		8,25		10,25		12,30	
d1	Minor Diameter	min	3,65		5,05		6,20		7,00	
		max	4,00		5,50		6,70		7,50	
dh	Head Diameter	min	14,50		19,40		23,00		27,50	
		max	16,50		23,00		26,60		31,50	
AF	Width across flat	min	AF10 -0,4		AF12 -0,4		AF15 -0,4		AF17 -0,5	
		max	AF10		AF12		AF15		AF17	
ds	Shaft Diameter	min	4,15		5,70		6,80		7,90	
h	Head Height	min	5,40		6,00		7,20		8,20	
		max	6,60		7,20		8,80		9,80	
p	Pitch	min	4,05		4,68		5,04		5,40	
		max	4,95		5,72		6,16		6,60	
L	Length	min	40	+2,0 -2,0	40	+2,0 -2,0	80	+2,0 -2,0	80	+2,0 -2,0
		max	300	+2,0 -2,0	600	+2,0 -2,0	600	+2,0 -2,0	600	+2,0 -2,0
L1	Thread Length	min	24	+1,5 -1,5	32	+1,5 -1,5	40	+1,5 -1,5	50	+1,5 -1,5
		max	75	+1,5 -1,5	150	+1,5 -1,5	150	+1,5 -1,5	150	+1,5 -1,5
L2	Shank Rips Length	min	11,00		11,00		11,00		11,00	
		max	13,00		13,00		13,00		13,00	
d2	Shank Rips Diameter	min	4,80		6,00		7,90		9,00	
		max	5,60		6,80		8,70		9,80	
Recess TX	Recess Size		25 / 30		40		40		40/50	

All dimensions and tolerances in mm.

RF Self-tapping screw coarse thread								
Self-drilling with full or part thread, Carbon Steel, Pan Head								
Tip: sharp, Type 17, Saw Thread and Type 17 & Saw Thread combined Shank Rips: obligatory Thread Cutting Line: optional Head Mark: optional								
Nominal diameter (d)			6		8		10	
d	Major Diameter	min	5,80		7,60		9,60	
		max	6,20		8,25		10,25	
d1	Minor Diameter	min	3,65		5,05		6,20	
		max	4,00		5,50		6,70	
dh	Head Diameter	min	13,00		16,60		20,50	
		max	13,80		17,40		21,50	
ds	Shaft Diameter	min	4,15		5,70		6,80	
h	Head Height	min	3,40		3,80		4,50	
		max	3,80		4,20		5,10	
p	Pitch	min	4,05		4,68		5,04	
		max	4,95		5,72		6,16	
L	Length	min	40	+2,0 -2,0	40	+2,0 -2,0	80	+2,0 -2,0
		max	300	+2,0 -2,0	600	+2,0 -2,0	600	+2,0 -2,0
L1	Thread Length	min	24	+1,5 -1,5	32	+1,5 -1,5	40	+1,5 -1,5
		max	75	+1,5 -1,5	150	+1,5 -1,5	150	+1,5 -1,5
L2	Shank Rips Length	min	11,00		11,00		11,00	
		max	13,00		13,00		13,00	
d2	Shank Rips Diameter	min	4,80		6,00		7,90	
		max	5,60		6,80		8,70	
Recess TX	Recess Size		25 / 30		40		40	

All dimensions and tolerances in mm.

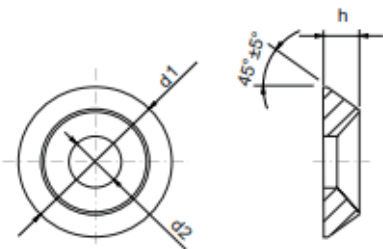
RF Washer					
Carbon Steel					
					
Nominal diameter (d)			6	8	10
d1	Outer Diameter	min	19,20	24,70	31,70
		max	19,80	25,30	32,30
d2	Inner Diameter	min	7,70	8,20	10,70
		max	8,30	8,80	11,30
h	Washer Height	min	4,50	4,70	5,70
		max	5,10	5,30	6,30

All dimensions and tolerances in mm.

Annex B
Minimum distances and spacing
Axially or laterally loaded screws in the plane or edge surface of cross laminated timber

Definition of spacing, end and edge distances in the plane surface unless otherwise specified in the technical specification (ETA or hEN) for the cross laminated timber:

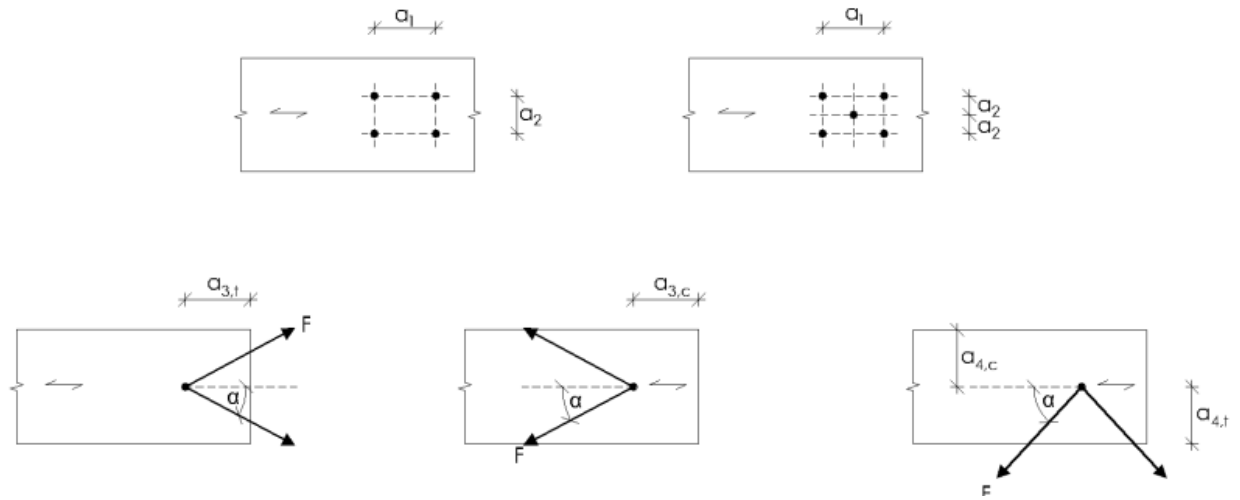

Definition of spacing, end and edge distances in the edge surface unless otherwise specified in the technical specification (ETA or hEN) for the cross laminated timber:

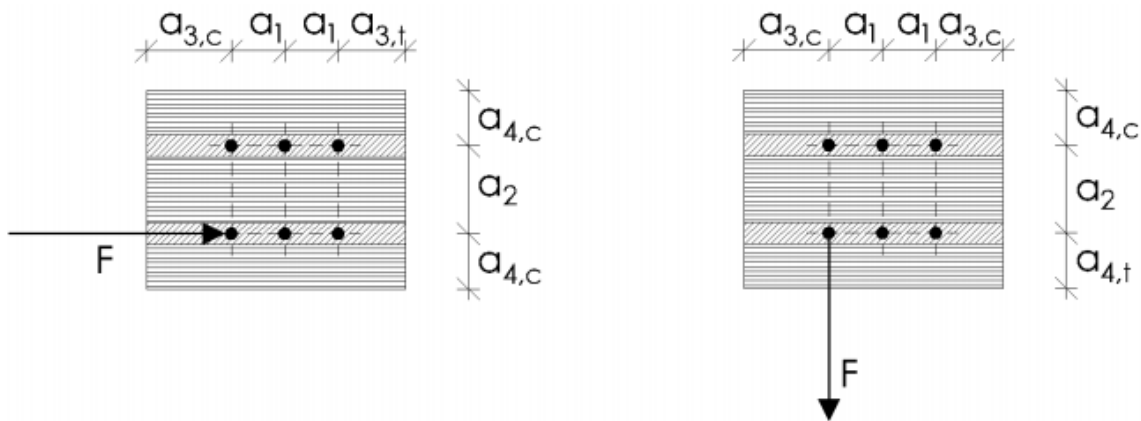

For screws in the edge surface, a_1 and a_3 are parallel to the CLT plane face, a_2 and a_4 perpendicular to CLT plane face.

Annex C

Thermal insulation material on top of rafters

RF Self-tapping screws for timber structures with an outer thread diameter of at least 6 mm may be used for the fixing of thermal insulation material on top of rafters.

The thickness of the insulation shall not exceed 300 mm. The rafter insulation must be placed on top of solid timber or glued laminated timber rafters or cross-laminated timber members and be fixed by battens arranged parallel to the rafters or by wood-based panels on top of the insulation layer. The insulation of vertical facades is also covered by the rules given here.

Screws must be screwed in the rafter through the battens or panels and the insulation without pre-drilling in one sequence.

The angle α between the screw axis and the grain direction of the rafter should be between 30° and 90°.

The rafter consists of solid timber (softwood) according to EN 338, glued laminated timber according to EN 14081, cross-laminated timber, or laminated veneer lumber according to EN 14374 or to ETA or similar glued members according to ETA.

The battens must be from solid timber (softwood) according to EN 338:2003-04. The minimum thickness t and the minimum width b of the battens is given as follows:

Screws $d \leq 8,0$ mm:	$b_{\min} = 50$ mm	$t_{\min} = 30$ mm
Screws $d = 10$ mm:	$b_{\min} = 60$ mm	$t_{\min} = 40$ mm
Screws $d = 12$ mm:	$b_{\min} = 100$ mm	$t_{\min} = 60$ mm

The insulation must comply with a European Technical Assessment.

Friction forces shall not be considered for the design of the characteristic axial capacity of the screws.

The anchorage of wind suction forces as well as the bending stresses of the battens or the boards, respectively, shall be considered in design. Additional screws perpendicular to the grain of the rafter (angle $\alpha = 90^\circ$) may be arranged if necessary.

The maximum screw spacing is $e_s = 1,75$ m.

Mechanical model

The system of rafter, heat insulation on top of rafter and battens parallel to the rafter may be considered as a beam on elastic foundation. The batten represents the beam, and the heat insulation on top of the rafter the elastic foundation. The minimum compression stress of the heat insulation at 10 % deformation, measured according to EN 826¹, shall be $\sigma_{(10\%)} = 0,05 \text{ N/mm}^2$. The batten is loaded perpendicular to the axis by point loads F_b . Further point loads F_s are from the shear load of the roof due to dead and snow load, which are transferred from the screw heads into the battens

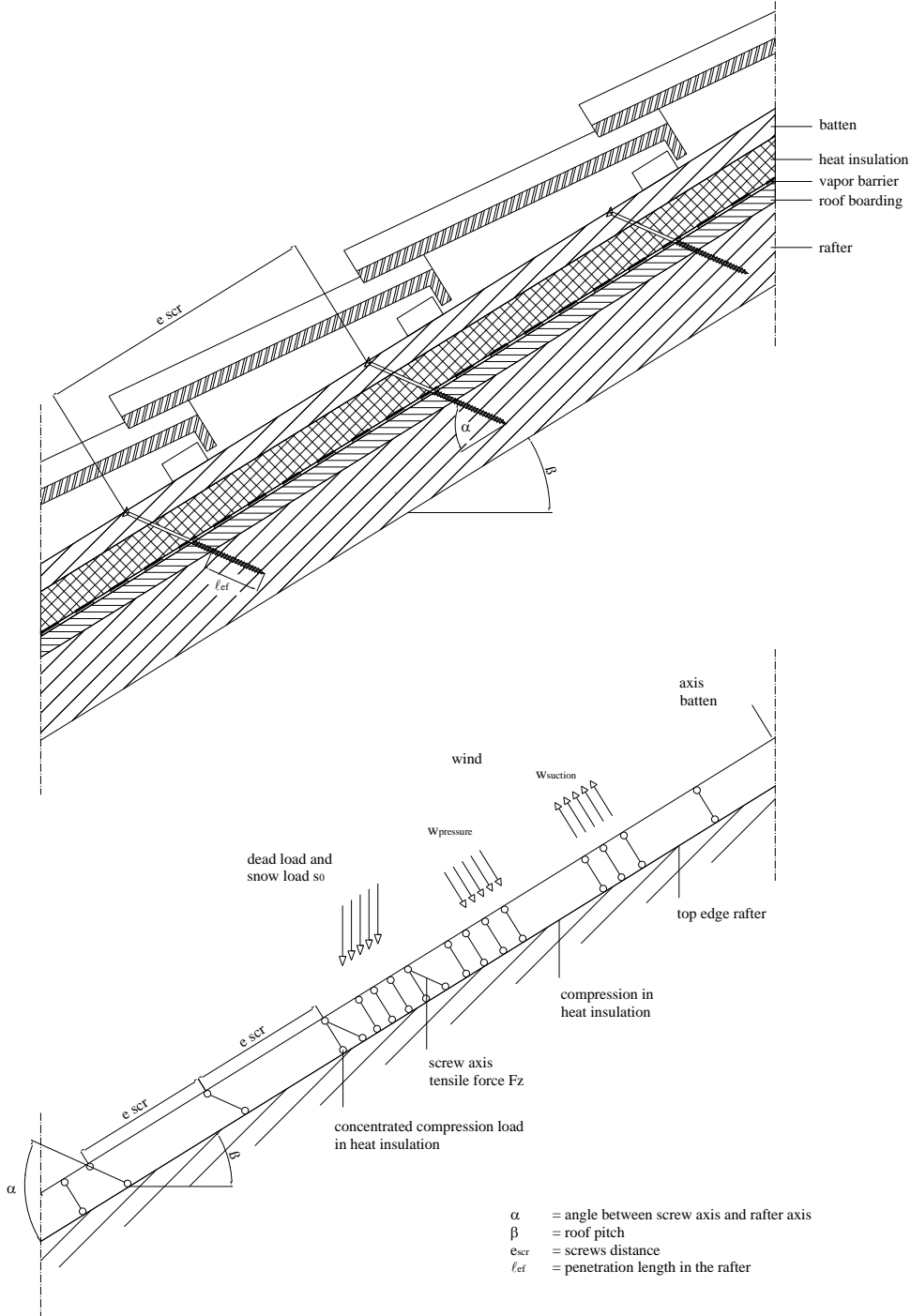

¹ EN 826:1996 Thermal insulating products for building applications - Determination of compression behaviour

Design of the battens

The bending stresses are calculated as:

$$M = \frac{(F_b + F_s) \cdot \ell_{\text{char}}}{4}$$

Where

$$\ell_{\text{char}} = \text{characteristic length } \ell_{\text{char}} = \sqrt[4]{\frac{4 \cdot EI}{w_{\text{ef}} \cdot K}}$$

EI = bending stiffness of the batten

K = coefficient of subgrade

w_{ef} = effective width of the heat insulation

F_b = Point loads perpendicular to the battens

F_s = Point loads perpendicular to the battens, load application in the area of the screw heads

The coefficient of subgrade K may be calculated from the modulus of elasticity E_{HI} and the thickness t_{HI} of the heat insulation if the effective width w_{ef} of the heat insulation under compression is known. Due to the load extension in the heat insulation the effective width w_{ef} is greater than the width of the batten or rafter, respectively. For further calculations, the effective width w_{ef} of the heat insulation may be determined according to:

$$w_{\text{ef}} = w + t_{\text{HI}} / 2$$

where

w = minimum width of the batten or rafter, respectively

t_{HI} = thickness of the heat insulation

$$K = \frac{E_{\text{HI}}}{t_{\text{HI}}}$$

The following condition shall be satisfied:

$$\frac{\sigma_{\text{m,d}}}{f_{\text{m,d}}} = \frac{M_{\text{d}}}{W \cdot f_{\text{m,d}}} \leq 1$$

For the calculation of the section modulus W the net cross section must be considered.

The shear stresses shall be calculated according to:

$$V = \frac{(F_b + F_s)}{2}$$

The following condition shall be satisfied:

$$\frac{\tau_{\text{d}}}{f_{\text{v,d}}} = \frac{1,5 \cdot V_{\text{d}}}{A \cdot f_{\text{v,d}}} \leq 1$$

For the calculation of the cross-section area the net cross section must be considered.

Design of the heat insulation

The compressive stresses in the heat insulation shall be calculated according to:

$$\sigma = \frac{1,5 \cdot F_b + F_s}{2 \cdot \ell_{\text{char}} \cdot w}$$

The design value of the compressive stress shall not be greater than 110 % of the compressive stress at 10 % deformation calculated according to EN 826.

Design of the screws

The screws are loaded predominantly axially. The axial tension force in the screw may be calculated from the shear loads of the roof R_s :

$$T_s = \frac{R_s}{\cos \alpha}$$

The load-carrying capacity of axially loaded screws is the minimum design value of the axial withdrawal capacity of the threaded part of the screw, the head pull-through capacity of the screw and the tensile capacity of the screw.

In order to limit the deformation of the screw head for Thermal insulation material thicknesses over 200 mm or with compressive strength below 0,12 N/mm², respectively, the axial withdrawal capacity of the screws shall be reduced by the factors k_1 and k_2 :

$$F_{ax,\alpha,Rd} = \min \left\{ k_{ax} \cdot f_{ax,d} \cdot d \cdot \ell_{ef} \cdot k_1 \cdot k_2 \cdot \left(\frac{\rho_k}{350} \right)^{0.8} ; f_{head,d} \cdot d_h^2 \cdot \left(\frac{\rho_k}{350} \right)^{0.8} ; f_{tens,d} \right\}$$

Where:

$f_{ax,d}$	design value of the axial withdrawal parameter of the threaded part of the screw
d	outer thread diameter of the screw
ℓ_{ef}	Point side penetration length of the threaded part of the screw in the batten, $\ell_{ef} \geq 40$ mm
α	Angle between grain and screw axis ($\alpha \geq 30^\circ$)
ρ_k	characteristic density of the wood-based member [kg/m ³]
$f_{head,d}$	design value of the head pull-through capacity of the screw
d_h	head diameter
$f_{tens,d}$	design tensile capacity of the screw
k_1	$\min \{ 1; 200/t_{HI} \}$
k_2	$\min \{ 1; \sigma_{10\%}/0,12 \}$
t_{HI}	thickness of the heat insulation [mm]
$\sigma_{10\%}$	compressive stress of the heat insulation under 10 % deformation [N/mm ²]

If k_1 and k_2 are considered, the deflection of the battens does not need to be considered. Alternatively, to the battens, panels with a minimum thickness of 22 mm from plywood according to EN 636, particle board according to EN 312, oriented strand board according to EN 300 or European Technical Approval and solid wood panels according to EN 13353 or cross laminated timber may be used.